

Energy savings with motors and drives

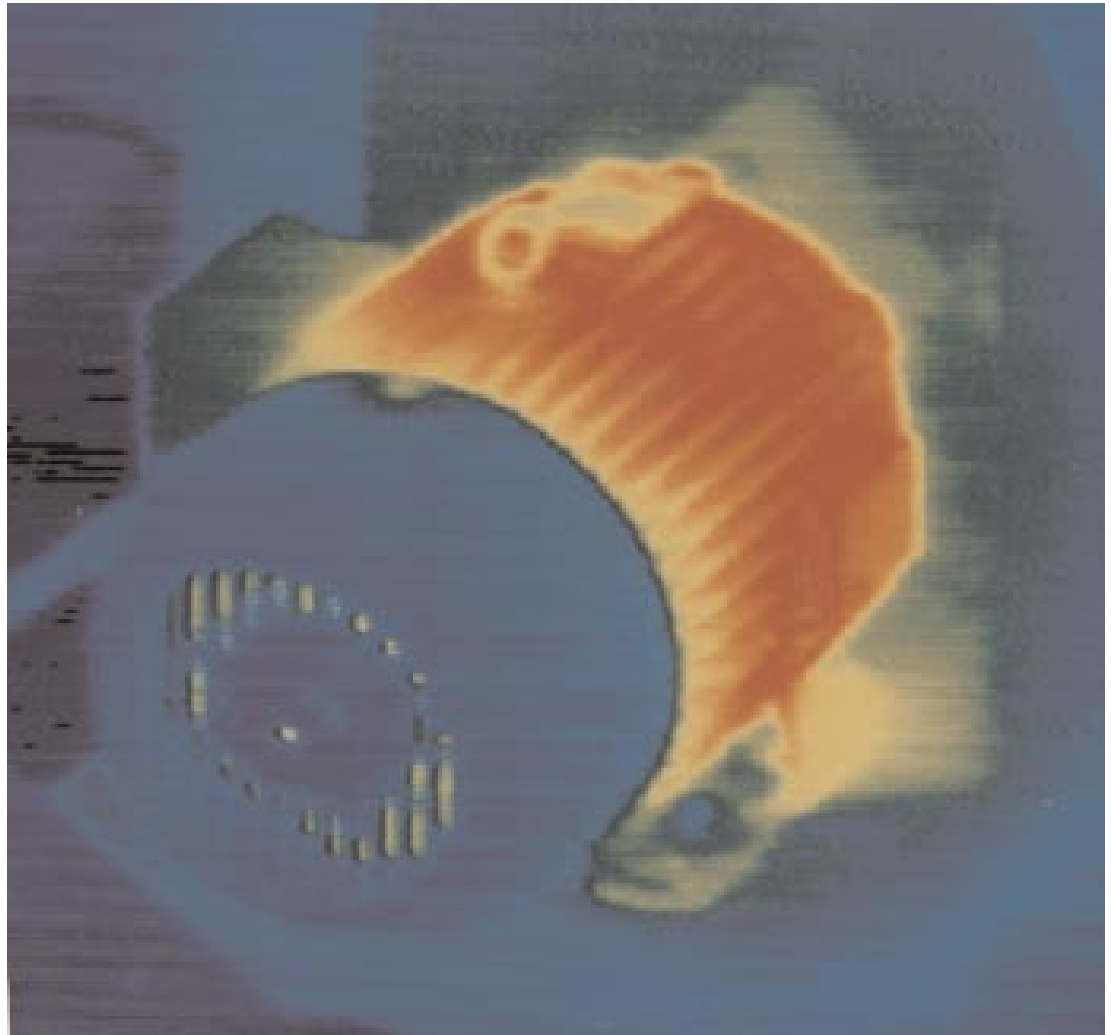

ENERGY EFFICIENCY

BEST PRACTICE
PROGRAMME

ENERGY SAVINGS WITH ELECTRIC MOTORS AND DRIVES

This Guide is No. 2 in the Good Practice Guide series and is aimed at those interested in reducing the operating costs of electric motors and drive systems.

This Guide updates and revises the information provided by Good Practice Guide 2 *Guidance Notes for Reducing Energy Consumption Costs of Electric Motor and Drive Systems*. It also incorporates material from Good Practice Guide 14 *Retrofitting AC Variable Speed Drives*, which it supersedes.

Prepared for the Department of the Environment, Transport and the Regions by:

ETSU
Harwell
Didcot
Oxfordshire
OX11 0RA

and

Doug Warne
REMACS
Piplars Cottage
Dusthouse Lane
Tardebigge
Near Bromsgrove
Worcestershire
B60 3AD

© Crown copyright 1998
First Published as *Guidance Notes for Reducing Energy Consumption Costs of Electric Motor and Drive Systems*, December 1989. 2nd edition 1990. Reprinted 12/91, 11/93, 7/94, 5/95, 6/96. Updated version published March 1998.

LIST OF RELEVANT TITLES IN THE GOOD PRACTICE GUIDE SERIES

- 36. COMMERCIAL REFRIGERATION PLANT: ENERGY EFFICIENT OPERATION AND MAINTENANCE
- 37. COMMERCIAL REFRIGERATION PLANT: ENERGY EFFICIENT DESIGN
- 38. COMMERCIAL REFRIGERATION PLANT: ENERGY EFFICIENT INSTALLATION
- 42. INDUSTRIAL REFRIGERATION PLANT: ENERGY EFFICIENT OPERATION AND MAINTENANCE
- 44. INDUSTRIAL REFRIGERATION PLANT: ENERGY EFFICIENT DESIGN
- 84. MANAGING AND MOTIVATING STAFF TO SAVE ENERGY
- 213. SUCCESSFUL PROJECT MANAGEMENT FOR ENERGY EFFICIENCY

Copies of these Guides may be obtained from:

Energy Efficiency Enquiries Bureau
ETSU
Harwell
Didcot
Oxfordshire
OX11 0RA
Tel 01235 436747. Fax 01235 433066. E-mail etsuenq@aeat.co.uk

Overseas customers please remit £3 per copy (minimum of £6) with order to cover cost of packaging and posting. Please make cheques, drafts or money orders payable to ETSU.

FOREWORD

This Guide is part of a series produced by the Government under the Energy Efficiency Best Practice Programme. The aim of the programme is to advance and spread good practice in energy efficiency by providing independent, authoritative advice and information on good energy efficiency practices. Best Practice is a collaborative programme targeted towards energy users and decision makers in industry, the commercial and public sectors, and building sectors including housing. It comprises four inter-related elements identified by colour-coded strips for easy reference:

- *Energy Consumption Guides*: (blue) energy consumption data to enable users to establish their relative energy efficiency performance;
- *Good Practice Guides*: (red) and *Case Studies*: (mustard) independent information on proven energy-saving measures and techniques and what they are achieving;
- *New Practice projects*: (light green) independent monitoring of new energy efficiency measures which do not yet enjoy a wide market;
- *Future Practice R&D support*: (purple) help to develop tomorrow's energy efficiency good practice measures.

If you would like any further information on this document, or on the Energy Efficiency Best Practice Programme, please contact the Environment and Energy Helpline on 0800 585794. Alternatively, you may contact your local service deliverer – see contact details below.

ENGLAND

London

Govt Office for London
6th Floor
Riverwalk House
157-161 Millbank
London
SW1P 4RR
Tel 020 7217 3435

East Midlands

The Sustainable Development Team
Govt Office for the East Midlands
The Belgrave Centre
Stanley Place
Talbot Street
Nottingham
NG1 5GG
Tel 0115 971 2476

North East

Sustainability and Environment Team
Govt Office for the North East
Wellbar House
Gallowgate
Newcastle-upon-Tyne
NE1 4TD
Tel 0191 202 3614

NORTHERN IRELAND

IRTU Scientific Services
17 Antrim Road
Lisburn
Co Antrim
BT28 3AL
Tel 028 9262 3000

North West

Environment Team
Govt Office for the North West
Cunard Building
Pier Head
Water Street
Liverpool
L3 1QB
Tel 0151 224 6401

South East

Sustainable Development Team
Govt Office for the South East
Bridge House
1 Walnut Tree Close
Guildford
Surrey
GU1 4GA
Tel 01483 882532

East

Sustainable Development Awareness Team
Govt Office for the East of England
Heron House
49-53 Goldington Road
Bedford
MK40 3LL
Tel 01234 796194

SCOTLAND

Energy Efficiency Office
Enterprise and Lifelong Learning Dept
2nd Floor
Meridian Court
5 Cadogan Street
Glasgow
G2 6AT
Tel 0141 242 5835

South West

Environment and Energy Management Team
Govt Office for the South West
The Pithay
Bristol
Avon
BS1 2PB
Tel 0117 900 1700

West Midlands

Regional Sustainability Team
77 Paradise Circus
Queensway
Birmingham
B1 2DT
Tel 0121 212 5300

Yorkshire and the Humber

Sustainable Development Unit
Govt Office for Yorks and the Humber
PO Box 213
City House
New Station Street
Leeds
LS1 4US
Tel 0113 283 6376

WALES

Business and Environment Branch
National Assembly for Wales
Cathays Park
Cardiff
CF10 3NQ
Tel 029 2082 5172

CONTENTS

Section		Page No.
1.	INTRODUCTION	1
2.	AC INDUCTION MOTORS	4
2.1	Motor Losses	4
2.2	Power Quality	5
3.	SWITCHING OFF THE MOTOR	6
3.1	Switching Off Techniques	6
3.2	Motor Wear from Frequent Switching	6
4.	REDUCING THE MOTOR LOAD	8
4.1	Energy Saving Opportunities in Common Motor Applications	8
4.1.1	Pumping	8
4.1.2	Fan Systems	8
4.1.3	Compressed Air Systems	8
4.1.4	Refrigeration Systems	9
4.1.5	Conveyors	9
4.2	Transmission Efficiency	10
4.2.1	Gearbox Efficiency	10
4.2.2	Belt Drives	10
4.2.3	Coupling Alignment	10
5.	REDUCING MOTOR LOSSES	11
5.1	Higher Efficiency Motors	11
5.1.1	Savings in Running Costs	12
5.2	Motor Repair	14
5.2.1	Repair or Replace?	14
5.3	Motor Sizing	16
5.3.1	Opportunities for Downsizing Motors	16
5.4	Practical Considerations When Changing a Motor	17
5.5	Reducing Losses in Lightly Loaded Motors	18
5.5.1	Permanent Connection in Star	18
5.5.2	Energy Optimising	19
5.6	Motor Maintenance	20
5.7	Motor Management Policy	20
5.7.1	Motor Management Agreements with External Contractors	20
6.	SLOWING DOWN THE LOAD	21
6.1	Types of Load	21
6.1.1	Variable Torque	21
6.1.2	Constant Torque	21
6.1.3	Constant Power	21
6.2	Energy Efficient Flow Reduction	22
6.3	The Effects of Static Head	22
6.4	Ways of Changing the Speed of the Driven Machinery	23
6.5	Variable Speed Drives (VSDs)	23
6.5.1	Equipment with an Integral VSD	25
6.5.2	Piggy-back Motors/VSDs	25
6.5.3	Energy Optimising Feature on VSDs	25
6.5.4	Practical Considerations When Using VSDs	25
6.6	Multiple Speed Motors (MSMs)	26
6.6.1	Different Types of MSMs	26

Section		Page No.
6.7	Changing the Pulley Ratio	28
6.8	Speed Control of Centrifugal Pumps	29
6.9	Speed Control of Fans	32
6.10	Speed Control of Air Compressors	34
7.	TAKING ACTION	35
7.1	Where to Start?	36
7.1.1	Estimating Running Costs	36
7.2	Deciding on a Course of Action	37
7.3	Making an Inventory of Motor Drives	38
7.4	Taking Measurements	39
7.4.1	Deciding Which Data to Collect	40
7.5	Establish Company Commitment and Policy	41
8.	FURTHER INFORMATION	42
8.1	Energy Efficiency Best Practice Programme and CADDET Publications	42
8.2	Other Publications	43
 APPENDICES		
Appendix 1	Motor Speed	44
Appendix 2	Motor Starting	45
Appendix 3	Use of Energy Optimisers on Refrigeration Compressors	46

1. INTRODUCTION

Electric motors are major users of electricity in industrial plant and commercial premises in the UK. Motive power accounts for almost half the total electrical energy used in the UK and for nearly two-thirds of industrial electricity use. Fig 1 shows the breakdown of energy consumption by different types of load.

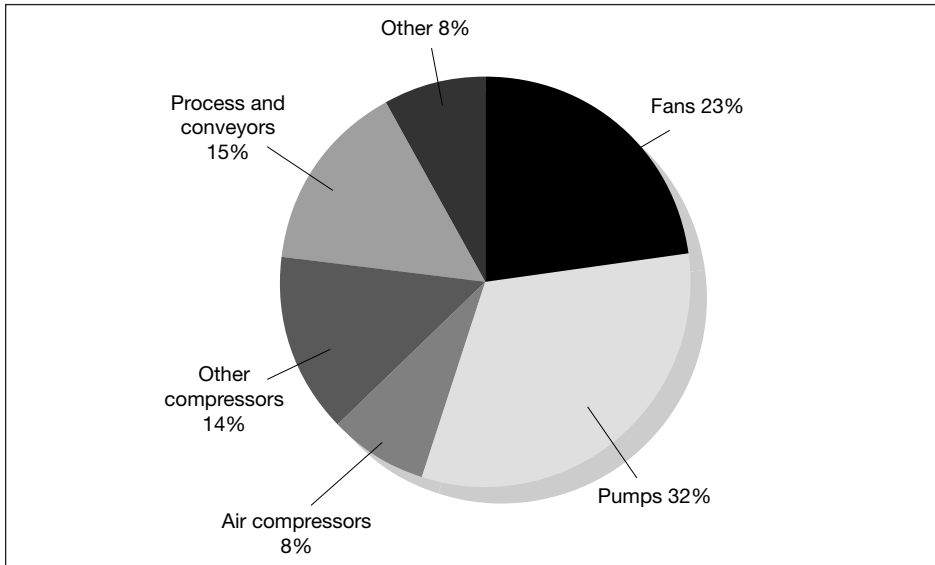

Fig 1 Energy consumption by induction motors up to 300 kW in industry

It is estimated that over ten million motors, with a total capacity of 70 GW, are installed in UK industry. The annual cost of running these motors is about £3,000 million, while a further £1,000 million is spent each year on electrical energy for motors in commercial applications. Most of these drives are powered by three-phase induction motors rated up to 300 kW.

The low cost of buying a motor can be deceptive. A modest-sized 11 kW induction motor costs as little as £300 to buy, but it could accumulate running costs of over £30,000 in ten years. The electricity bill for a motor for just one month can be more than its purchase price.

Even though the capital cost is sometimes quite small, the high lifetime running costs mean that it is important to consider carefully the options that exist when replacing motor drives or installing new equipment.

Several factors help to obscure the high ongoing cost of motors. Induction motors are reliable, generally quiet and often installed in out of the way locations around the plant. The large numbers of motors operating in most industrial plants also makes it difficult for a user to identify the best opportunities for saving energy.

The choice of techniques and equipment to reduce energy consumption by motor drives can also seem bewildering. A range of options exists from low-cost measures such as time switches to sophisticated variable speed drives (VSDs). The vast choice can make it difficult to decide on the best option for a particular application.

Even small efficiency improvements produce impressive cost savings. For example, if all motors in the UK were higher efficiency motors (HEMs), the 3% energy saving would be worth £120 million/year. Now that HEMs are available without a price premium, this is a sure way of achieving savings at no extra cost. VSDs have the potential to save considerably more, but the payback may be six months or longer.

On an industrial site with an electricity bill of £150,000/year, an average of £100,000/year will be spent on running motors. Annual savings of £3,000 can be achieved by using higher efficiency motors and £15,000 or more from fitting variable speed drives. The savings from paying attention to the efficiency of the transmission, the driven machinery and the system the machine is driving can be at least the same again.

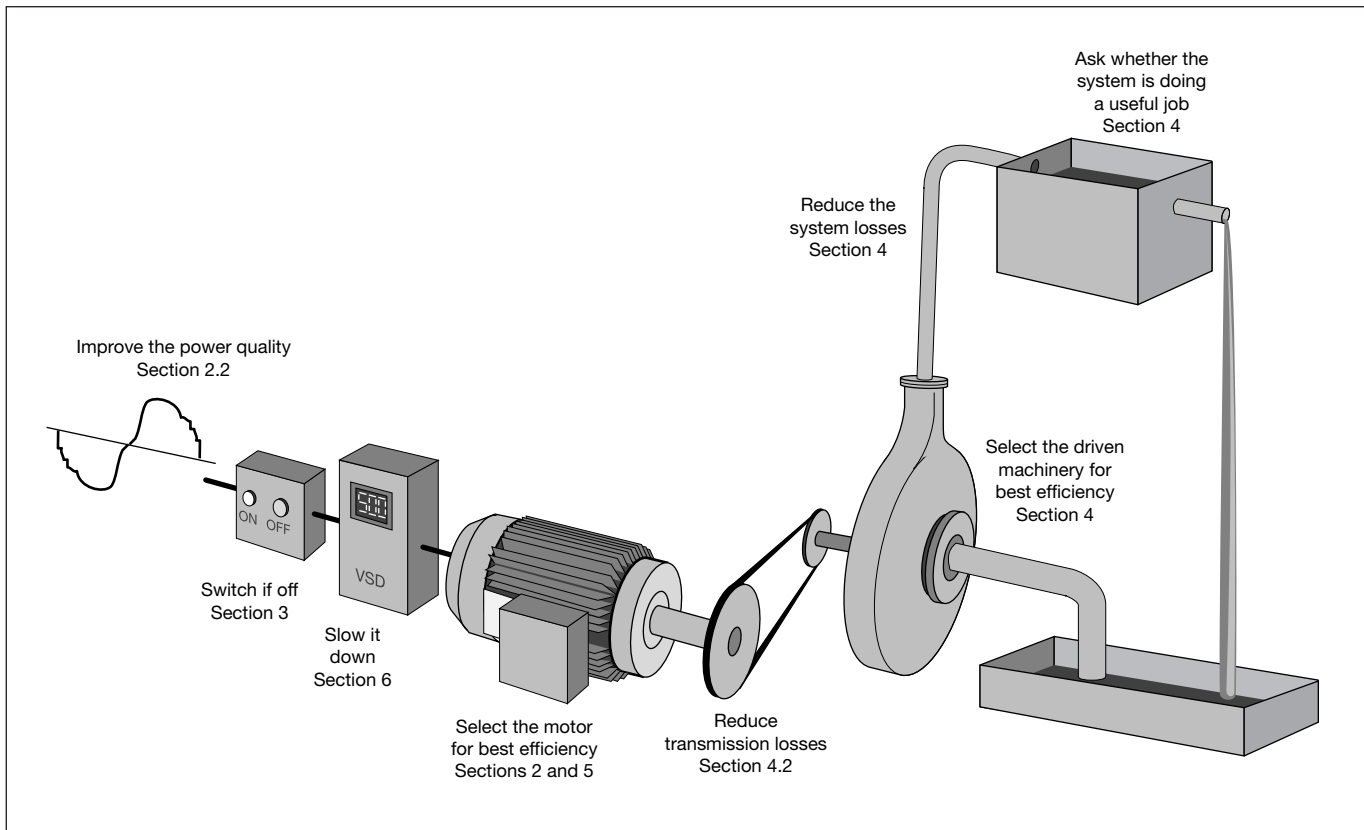

Fig 2 Energy saving opportunities in a drives system

Just concentrating on the drive itself can mean that significant and often low cost energy saving opportunities in the system that the drive is powering can be missed. The option of simply switching the motor off when not needed shouldn't be overlooked either!

Fig 2 shows where to look in this Guide for advice on each of the inter-related energy saving opportunities.

This Good Practice Guide gives a practical approach to identifying and implementing cost-effective energy saving opportunities, particularly for AC induction motors up to 300 kW. Further information and advice are available from equipment suppliers or the Energy Efficiency Enquiries Bureau at ETSU.

ENERGY SAVING CHECKLIST

1. Is the Equipment Still Needed?

- Check that changing requirements have not eliminated the need for the equipment altogether.

2. Switching the Motor Off (see Section 3)

- Time the switching according to a fixed programme or schedule.
- Monitor system conditions, e.g. high or low temperature, and switch off the motor when it is not needed.
- Sense the motor load so that the motor is switched off when 'idling.'

3. Reducing the Load on the Motor (see Section 4)

There is no point in optimising the drive if what the motor is driving is fundamentally inefficient.

- Is the system doing a useful and necessary job?
- Is the transmission between motor and driven equipment efficient?
- Is the driven machine efficient?
- Are maintenance programmes adequate?
- Have losses due to the pipework, ducting, insulation, etc. been minimised?
- Is the control system effective?

4. Minimising Motor Losses (see Section 5)

- **Always specify higher efficiency motors where feasible. These are now available without any cost premium.**
- When a motor fails, ensure that proper care and attention is given in the repair process so as to minimise energy losses.
- Avoid using greatly oversized motors.
- Consider permanent reconnection in star as a no-cost way of reducing losses from lightly loaded motors.
- Check that voltage imbalance, low or high supply voltages, harmonic distortion or a poor power factor are not causing excessive losses.

5. Slowing Down the Load (see Section 6)

In pump or fan applications where the cube law applies, even a small reduction in speed can produce substantial energy savings.

- **Use variable speed drives (VSDs) where several discrete speeds or an infinite number of speeds are required. Although often the most expensive option, the many benefits and large energy savings from VSDs make them the usual choice for speed control.**
- Use multiple speed motors (MSMs) where two (and up to four) distinct duties exist.
- For belt drives only, a low-cost option is to change the pulley ratio.

2. AC INDUCTION MOTORS

Most electrical drives in industry are powered by induction motors. The most common form, the cage induction motor, is simple, low cost and reliable. Different speed motors are produced by altering the number of poles (see Section 6.6 and Appendix A1.1). Methods for starting motors are described in Appendix 2.

The main elements of a cage induction motor are the stator and rotor cores (a stack of iron laminations), an insulated stator winding, and rotor conductors formed by the casting of an aluminium cage into the rotor core. In the totally enclosed induction motor shown in Fig 3, ventilation is achieved by an external shaft-mounted fan that blows air over the frame, thus cooling its external surfaces.

The ubiquitous induction motor can go on quietly consuming energy without anyone noticing. How many pumps and fans are hidden away in your plant?

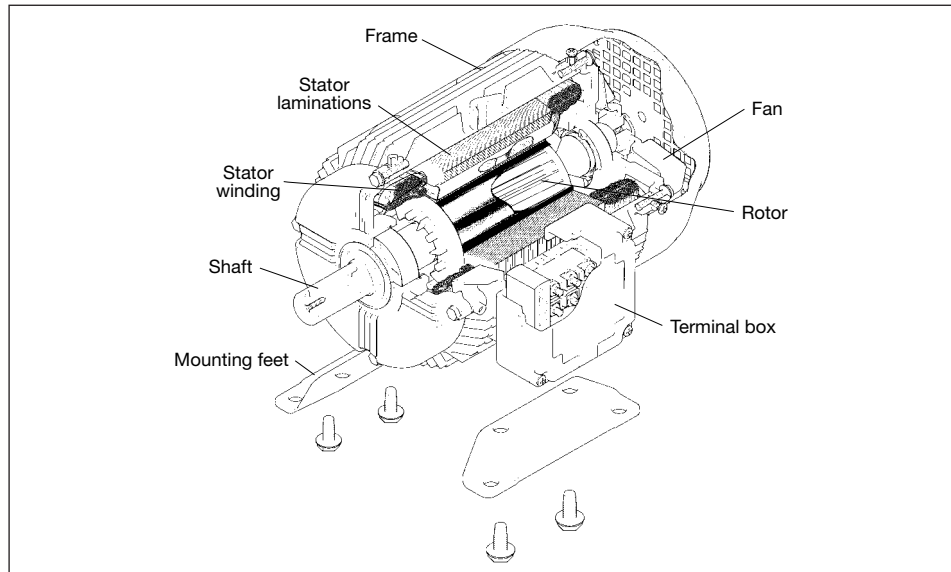

Fig 3 Cross-section through a cage induction motor

2.1 Motor Losses

Power losses in induction motors can be grouped into two main components. These are:

Fixed losses, i.e. independent of motor load:

- iron or magnetic loss in the stator and rotor cores;
- friction and windage loss.

Losses proportional to the motor load:

- resistive (I^2R) or copper loss in the stator and rotor conductors;
- stray loss caused by components of stray flux.

A typical composition of motor losses and their variation with load is shown in Fig 4. Although the losses increase with motor load, they are less significant at higher motor loads (see Fig 5). These two graphs are important in understanding how to select motors for the lowest energy costs.

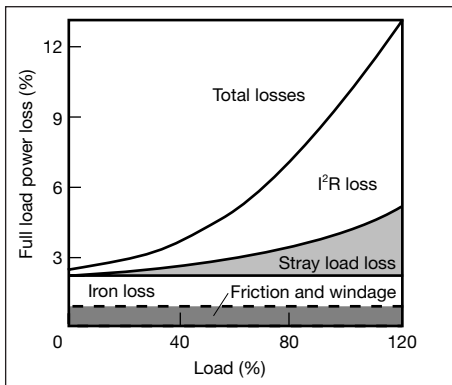

Fig 4 Power losses in cage induction motors

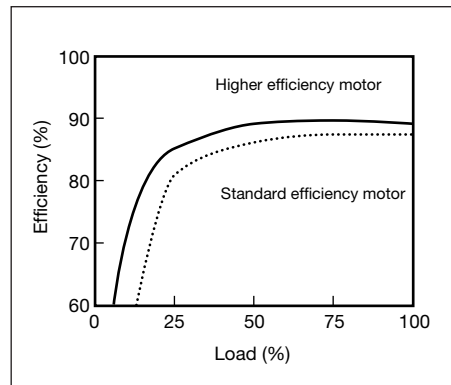

Fig 5 Variation in efficiency with load for a standard and a higher efficiency 7.5 kW induction motor

Fig 6 shows the specifications given on a typical modern nameplate. Efficiency is not generally shown on a rating plate - but this information can be obtained from the manufacturer or by reference to data sheets.

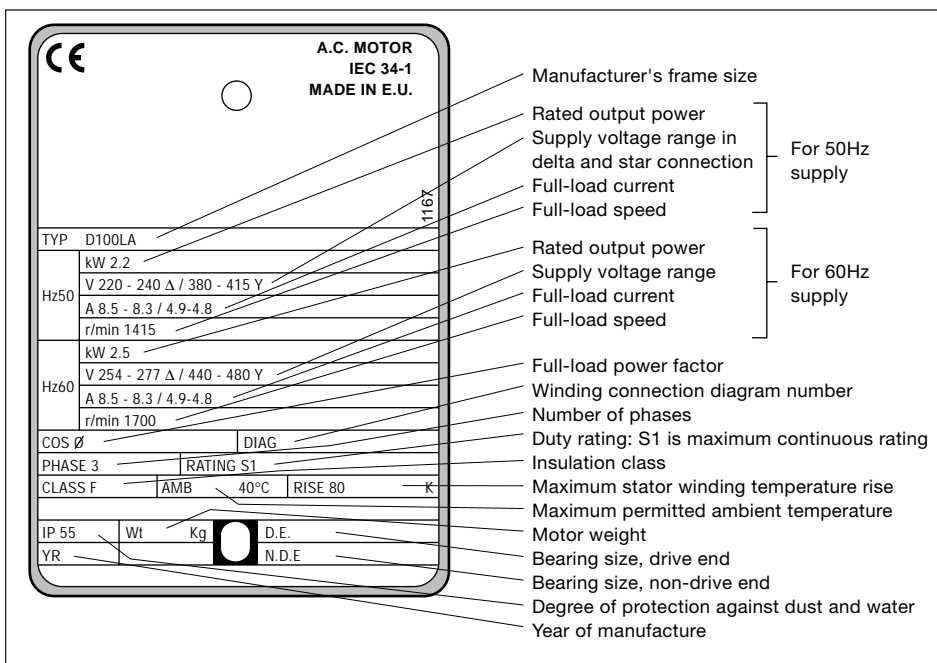

Fig 6 Typical rating plate details

While all low voltage induction motors in the UK are constructed to strict standards, these do not yet include energy efficiency.

The rated motor power is the shaft power, i.e. the useful mechanical power that it can provide to turn the load. But because the motor itself has losses, the power drawn by the motor at full load will be greater than the rated shaft power. For example, at full load, a 30 kW motor that is 92.5% efficient will draw $(30/0.925) \text{ kW} = 32.4 \text{ kW}$.

2.2 Power Quality

Poor power quality - due to such factors as harmonic distortion, voltage imbalance or a particularly low or high supply voltage - can have a detrimental effect on motor power consumption.

The effects of harmonic distortion and voltage imbalance on electric motors are discussed in Publication No. 116 *Electrical Energy Efficiency* and Publication No. 111 *Common Power Quality Problems and Best Practice Solutions* from the Copper Development Association (see Section 8.2 for contact details).

The rudiments of electricity are discussed in Fuel Efficiency Booklet 9A *The Economic Use of Electricity in Industry*. The measurement of power is also considered in Section 7.4.

Just switching a machine off over the weekend can save a surprising amount. There are 64 hours between 5 pm on Friday and 9 am on Monday - that's 3,328 hours over the year. At 5p/kWh, this represents an annual cost of £166/kW of unnecessary load.

Good Practice Case Study GPCS137 describes the air sequencer system at Land Rover, which achieved energy savings of £24,000/year through switching compressors on and off to match the demand for air.

3. SWITCHING OFF THE MOTOR

The simplest way of reducing energy consumption is to switch off the motor when it is not needed. There are a variety of ways of controlling switching off which are often specific to the application. This Section provides a series of pointers to possible opportunities and practical techniques.

3.1 Switching Off Techniques

Techniques available for switching off plant include:

- *Manual switching off.* This method is the cheapest, but because it relies on people, it is also the least reliable. Reasons for this include: simply forgetting; no single person being responsible for the equipment; and people finding it inconvenient to have to wait for the equipment to start up again.
- *Interlocking,* e.g. an extract or fan only switched on when a woodworking centre or welding equipment is switched on.
- *'Bang-bang' control.* Rather than running a machine continuously at part load, allow it to run on or off within an upper and lower limit, e.g. fit a large water storage tank to allow a pump to cycle on/off rather than use a recirculation system or throttle regulation.
- *Time switch.* Fit a time switch to ensure the equipment is on only when it is needed.
- *Sequencing of multiple motor loads,* e.g. air or refrigeration compressors. The optimum selection of machines in a multiple installation is selected to achieve the desired pressure or temperature. By matching different sized machines to meet the precise demand, inefficient operation at part load - or even no load - can be avoided. Some controllers can also sequence the use of the machines to equalise wear.
- *Load sensing.* Many motors spend long periods of time running with no useful load, but they may still be having to overcome significant losses in gearboxes, couplings, belts, flywheels or other transmission components. Controls are available that detect that the motor is in a 'no-load' running condition, and after a pre-set time in this state, switch off the motor. In some applications where direct feedback from the load is difficult, e.g. presses and conveyors, this can represent a cost-effective solution.

3.2 Motor Wear from Frequent Switching

Switching motors on and off more often can be a very simple way to save energy, but frequent starts increase wear on belt drives and bearings, while the extra heating due to high starting current can shorten the life of the motor insulation system. Any added maintenance or repair costs arising from the extra wear on the motor due to more frequent switching on and off should be taken into account when assessing the feasibility of this energy saving technique.

Fig 7 shows recommended permitted starting frequencies for four-pole motors. The starting frequency limits are lower for high-load inertias, for motors operating nearer full load and for higher speed motors (two-pole). Motor and load inertias can be calculated from data available from the manufacturer - but in practice, the load inertia is usually much larger than the motor inertia.

As the starting frequency may not be known when the controller is installed, it is recommended that the system is monitored carefully during the initial operating period to ensure that the frequency of starting is within the

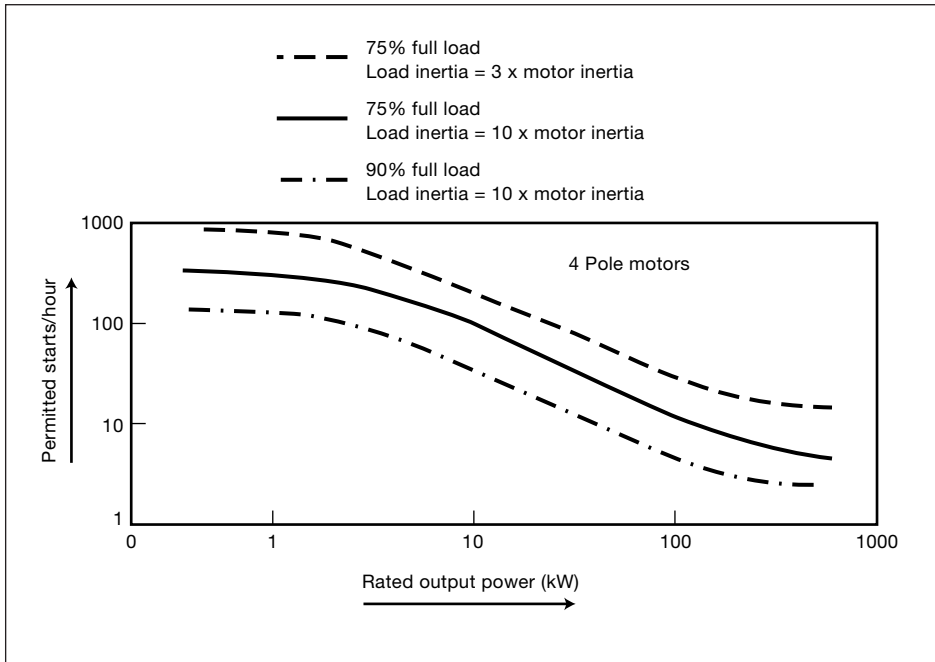

Fig 7 Recommended limits on starting frequency

manufacturer's guidelines. Fig 7 shows that larger motors have lower limits; reference should therefore be made to the manufacturer for motors over 200 kW.

Soft starters (see Appendix 2) provide a method of reducing the wear during start-up and can increase the starting frequency by 2-4 times. Consideration should therefore be given to fitting these devices if frequent starting occurs.

CASE STUDY: SWITCHING OFF THE MOTOR

The Birmingham plant of AP Pressings contains about 100 presses producing components for the motor industry. Many of the presses are needed throughout the day, but the press motors were sometimes left idling for long periods of time during tea breaks, lunch breaks and at the end of shifts. Although the motors were not loaded during the idling period, internal losses meant that they still used an average of 14% of the rated power. Automatic load detectors were fitted to seven of the presses to switch off the motors if they were left in the idling condition for more than a preset time. Savings of £630/year were obtained for a total expenditure of £660, giving a payback period of just over a year.

Further details are in Good Practice Case Study GPCS215 *Automatic Switch-off of Power Presses*, available from the Energy Efficiency Enquiries Bureau.

Efficiency is doing the thing right, effectiveness is doing the right thing. Don't spend a lot of effort making an ineffective system more efficient.

Start by looking at the machinery and system the motor is driving - the energy savings here can often exceed those in the drive.

Salt Union Ltd trimmed the impeller of a pump at its salt production plant at Runcorn in Cheshire. Energy savings of £8,900/year were achieved for a cost of only £260. See Good Practice Case Study GPCS300 for more details.

An energy manager at the Royal Mint realised that, because the natural ventilation was so good, a 22 kW extraction fan was not actually needed. Turning the fan off saved £10,000/year.

4. REDUCING THE MOTOR LOAD

When reviewing the efficiency of a motor drive system, the first question should be whether the load driven by the motor (i.e. everything from the shaft to the result of the work the system is performing) can be reduced or even whether the equipment is still actually needed. There is little point in optimising the motor and its controls, if the driven equipment and the process it powers are inefficient. Many of the techniques for reducing the load are inexpensive and thus provide an excellent starting point.

The following Sections provide advice on the main ways of reducing the load on the motor.

4.1 Energy Saving Opportunities in Common Motor Applications

4.1.1 Pumping

- Select an efficient pump and operate it close to its rated design flow and head.
- If consistently underloaded, install a smaller impeller or trim the existing one.
- Pay particular attention to pumps in parallel - adding more pumps can make the whole system progressively less efficient.
- Minimise the number of sharp bends in pipework.
- Consider improving pump efficiency by using low friction coatings.
- Always use lower friction piping from new and consider refurbishing older pipework.
- Check pump inlet pressures are satisfactory.
- Maintain the pump. Without maintenance, pump efficiency could fall by 10% of its value when new.
- For large pumps, set up a condition monitoring programme to calculate the optimum time for refurbishment.

4.1.2 Fan Systems

- Select an efficient fan.
- Keep filters clean to minimise pressure drops.
- Clean blades regularly.
- Avoid unnecessary pressure drops in ducting.
- Fit dampers to seal off the extract systems from unused machinery.
- Install a control to switch on the fan only when it is needed.
- Utilise existing systems for reducing fan speed by altering pulley sizes.
- Where a bank of fans exists, switch units on and off to suit the demand.

4.1.3 Compressed Air Systems

Compressed air is not free - it costs the equivalent of 50 p/kWh.

- Consider alternatives to compressed air, e.g. using electric instead of air tools.
- Match the compressor size to demand. If several compressors are needed, use a controller/sequencer.
- Consider installing a small compressor for use during low demand periods.
- Maintain equipment regularly, avoiding the use of low quality spares.
- Generate at the lowest acceptable pressure.
- Use waste heat from the compressors for space or water heating.
- Check for leaks regularly and repair promptly.

- Zone the system and isolate pipework sections when not in use.
- Remove or shut off permanently unused pipework.
- Use solenoid valves to isolate machinery which is prone to leakage.
- Check pressure drops across filters and replace promptly when drops become excessive.
- Avoid treating the whole system to an unnecessarily high standard.

4.1.4 Refrigeration Systems

- Ensure that the cooled space temperature is not lower than necessary. A 1°C increase in store temperature gives a 2 - 4% energy saving.
- Ensure that the load is as cool as possible when it enters the refrigerated space. Where possible, investigate pre-cooling of the load using ambient air or water.
- Minimise periods for which cold store doors are open.
- Repair damaged door seals and/or insulation.
- Reduce the heat input from auxiliaries either by relocating lighting, fans, pumps etc. externally or by using higher efficiency models.
- Check defrost operation. Adjust the timers or fit defrost-on-demand controls.
- Consider installing a more efficient compressor with in-built capacity control.
- Control the fan to suit the cooling requirement.
- Check for leaks and stop them promptly. Bubbles in the liquid line sightglass indicate undercharging and possible leakage.
- Ensure free air can circulate around condensers. Keep them away from walls and out of direct sunlight.

4.1.5 Conveyors

- Use sensors, e.g. an interruptible light beam or motor current sensor, to detect when the conveyor is unloaded and switch it off.
- Consider 'zoning' the conveyor so that sections that are not in use can be switched off.

4.2 Transmission Efficiency

Once the load has been examined to ensure that it is being used effectively, attention should be given to the transmission system.

4.2.1 Gearbox Efficiency

Most parallel axis gears have a high efficiency. However, careful selection and maintenance of the gearbox will improve performance.

Gearbox losses depend on:

- The type of gear. A worm gearbox typically has an efficiency of 85 - 90% compared to 98.0 - 98.5% for a helical one.
- Gearbox selection. Minimising the number of meshes produces maximum efficiency, but increases the cost and size of the gearbox.
- Gear quality. The friction loss depends on the accuracy and quality of the gear surface. It is therefore important to use gearboxes supplied by reputable, high quality manufacturers.
- Type of bearing.
- Lubrication.
- Gear condition.

Attention to all these details will increase gearbox efficiency.

4.2.2 Belt Drives

- Modern flat or wedge belts can be more efficient than traditional 'V' belts (see Table 1). In addition, 'V' and wedge belts deteriorate with age by about 4% of efficiency - plus a further 5 - 10% if the belts are poorly maintained.
- Oversizing or undersizing 'V' belts can produce additional losses.
- Ensure belts are properly tensioned.
- If one belt on a multiple belt drive fails, replace them all. Ideally avoid multiple belt drives altogether as differences in tension are inevitable.
- Check pulley alignment. For belt drives, mounting the motor on slide rails allows both alignment and belt tension to be easily adjusted.

It is important that the motor and load shafts are parallel. The pulleys can be aligned by running a tightly-drawn cord across the face of both the large pulley and the smaller pulley. If the drive shafts are parallel, the cord will be parallel to the faces of both pulleys.

- When the pulleys need replacing, it is particularly cost-effective to consider changing the drive type.

Table 1 Comparative belt efficiency

Type of belt	Typical improvement
'V'	—
Wedge/cogged wedge	2%
Synchronous/flat/ribbed	5 - 6%

4.2.3 Coupling Alignment

Motor manufacturers publish information on simple alignment checks using feeler gauges: larger sites may benefit from even easier to use - but more expensive - laser alignment equipment.

5. REDUCING MOTOR LOSSES

This Section describes practical ways of reducing power losses from AC induction motors and indicates the savings to be made from three key energy efficiency measures, i.e.:

- Higher efficiency motors (HEMs) (see Section 5.1) are now available **without any cost premium** and can produce useful savings in all applications.
- Careful motor repair ensures that motor losses are minimised (see Section 5.2).
- Use correctly-sized motors to avoid the greater losses from part-loaded motors (see Section 5.3).

In addition, two techniques for reducing the losses on lightly-loaded motors are discussed, i.e.:

- Permanent reconnection in star (see Section 5.5.1).
- ‘Energy optimising’ controls (see Section 5.5.2).

The efficiency of a motor may seem high compared to that of the pump or fan it is driving, but 1 kW of heat lost from a 7.5 kW motor is a lot of wasted power. You may even be paying twice for this lost heat, e.g. the heat losses from the motor in a refrigeration store represent more heat to be removed.

Although the opportunity for cost savings from an individual motor are usually modest, implementing energy efficiency measures on a large number of motors across the site can produce substantial savings. A motor management policy (see Section 5.7) should be considered to simplify decision-making.

5.1 Higher Efficiency Motors

Over the past 30 years, continuous pressure to reduce the capital cost of motors led to a reduction in the iron and copper content of the motor, with a resulting decrease in efficiency.

Motor manufacturers are now competing to produce motors with improved efficiency. Most offer ‘energy efficient’ or ‘high efficiency’ motors - sometimes as their standard product - while some even offer higher efficiency motors without any cost premium. This is possible because motor losses have been reduced by the use of new materials, better design and more attention to the manufacturing process. The price premium associated with traditional HEMs - which merely used more active material - is no longer necessary. Even more efficient motors are expected to become available at a price premium - giving a constantly changing situation.

Because higher efficiency motors contain smaller, more efficient cooling fans and have lower magnetic loadings, they tend to be much quieter. This is an advantage in situations where noise is a critical factor. HEMs generally also have a better power factor, which can give further savings through a reduction in the kVA maximum demand charge.

Future Practice R&D Profile 50 outlines the development of a Brook Hansen range of higher efficiency motors and explains in detail how improvements were achieved.

Although a 2% increase in efficiency for a 30 kW motor may not seem significant, this represents a reduction of about a quarter of the power loss. If the motor is running continuously, this could reduce the energy bill for this motor by almost £300/year, worth nearly £3,000 over a typical ten-year lifetime.

5.1.1 Savings in Running Costs

The energy consumed by a motor in its first month of operation can cost as much as the motor itself. This is why even a saving of just 3%* is worthwhile.

Since there is no agreed definition of an HEM, users should look at the motor data sheet to obtain its efficiency at the expected load point. Typical data taken from leading manufacturers are shown in Table 2. This Table shows that the larger the motor, the higher the savings; the savings for part-loaded motors are also significant and, in some cases, actually higher than at full load.

The information given in the last column of Table 2 is useful for estimating the potential savings from replacing an existing motor with a new, higher efficiency motor. It is, however, important to calculate the savings for a particular motor, duty and electricity cost.

* The 3% efficiency improvement quoted is only an average - it will be larger on smaller motors but less on bigger motors.

Table 2 Efficiency data for four-pole motors

Rated		'Standard' efficiency	'Higher' efficiency	Annual cost with a 'standard' efficiency motor	Annual saving**	Typical efficiency of an approx 20-year old motor
3.0 kW	FL	82.0%	84.5%	£1,463	£43	81%
	3/4 x FL	82.0%	85.5%	£1,098	£45	81%
	1/2 x FL	79.0%	85.0%	£759	£54	79%
	1/4 x FL	70.0%	80.0%	£429	£54	
7.5 kW	FL	87.0%	89.0%	£3,448	£77	85%
	3/4 x FL	87.0%	89.5%	£2,586	£72	85%
	1/2 x FL	86.0%	89.0%	£1,744	£59	82%
	1/4 x FL	81.0%	85.0%	£926	£44	
15 kW	FL	90.0%	92.0%	£6,667	£145	88%
	3/4 x FL	90.0%	92.5%	£5,000	£135	88%
	1/2 x FL	90.0%	91.5%	£3,333	£55	86%
	1/4 x FL	81.0%	88.0%	£1,667	£147	
30 kW	FL	90.5%	92.5%	£13,261	£286	90%
	3/4 x FL	90.5%	92.5%	£9,948	£215	90%
	1/2 x FL	89.5%	91.7%	£6,704	£161	88%
	1/4 x FL		85.1%			
75 kW	FL	93.5%	94.4%	£32,086	£306	93%
	3/4 x FL	93.5%	94.4%	£24,064	£229	93%
	1/2 x FL	92.5%	93.4%	£16,216	£156	

(** Annual saving using a higher efficiency motor compared to a standard efficiency motor, assuming the motor runs for 8,000 hrs/year at a cost of 5 p/kWh.)

Calculating the Savings from Using a Higher Efficiency Motor

The annual saving achieved by installing a higher efficiency motor in place of an existing standard efficiency machine is calculated using the formula:

$$\text{Annual saving} = \text{hrs} \times \text{kW} \times \% \text{ FL} \times \text{p/kWh} \times \left(\frac{1}{\eta_{\text{std}}} - \frac{1}{\eta_{\text{hem}}} \right)$$

where: hrs = annual running time in hours
 kW = motor rating in kW (i.e. shaft or output power)
 % FL = fraction of full load at which motor runs
 p/kWh = electricity cost in p/kWh
 η_{std} = efficiency of standard motor at the load point
 η_{hem} = efficiency of higher efficiency motor at the load point.

Efficiencies for older motors can be difficult to obtain - Table 2 gives some guidance.

Consider the example of a 30 kW motor running for 8,000 hrs/year at three-quarters load with an energy cost of 5 p/kWh. At three quarters load, a standard motor would give 90.5% efficiency and a higher efficiency motor 92.5%. Using the formula given above:

$$\text{Annual saving} = 8000 \times 30 \times 0.75 \times 5 \times [(1/90.5) - (1/92.5)] = \mathbf{\pounds 215}.$$

Quick Method

A quick - but low - estimate of the saving can be obtained by multiplying the running cost by the difference in efficiencies. For the example above, the difference in efficiencies is 2%.

$$\text{Estimated annual saving} = 8000 \times 30 \times 0.75 \times 5 \times [2\%] = \mathbf{\pounds 180}.$$

Some motor suppliers will install a higher efficiency motor temporarily to demonstrate the energy savings. This overcomes the difficulty in obtaining an accurate value for the efficiency of an older motor.

Now that many motors are more energy efficient as standard, it is worth doing similar calculations to determine the real cost of buying a cheaper but, possibly, less efficient alternative.

CASE STUDY: USING HIGHER EFFICIENCY MOTORS

Replacing standard efficiency motors, rated between 1.1 kW and 30 kW, on a variety of fans and pumps at the Delta Extruded Metals Company Ltd's plant at West Bromwich with higher efficiency motors produced energy savings of £408/year.

Further details are in Good Practice Case Study GPCS162 *High Efficiency Motors on Fans and Pumps*, available from the Energy Efficiency Enquiries Bureau.

5.2 Motor Repair

Many motors - particularly large or special types - are repaired several times during their working life. Proper care and attention must be given to the repair process. If they are not there can be a significant reduction in efficiency.

It is important to pay attention to:

- the gauge and number of turns of the replacement wire;
- the temperature at which the stator is heated for winding removal;
- use of correct spares;
- general mechanical handling.

Tests have shown that rewinding a motor can permanently reduce its efficiency by over 1%, but if the rewind is done properly, the reduction can be kept to 0.5% or less.

The environmental impact of scrapping old motors and replacing them with new ones is generally outweighed by the reduction in carbon dioxide emissions through the use of more efficient motors.

In practice, it is rarely economic to repair standard induction motors with a rating of less than 7.5% kW - some motor users choose a much higher cut-off point. Badly damaged motors should be scrapped rather than repaired.

A joint Association of Electrical and Mechanical Trades (AEMT)/Energy Efficiency Best Practice Programme Good Practice Guide on rewinding is available from the AEMT (see Section 8.2 for contact details). This Guide is based on the results of extensive tests covering all major aspects of motor repair. When selecting a repair company, confirm that the company adheres to the checklist given in the Guide and thus will minimise motor losses as far as is practical.

5.2.1 Repair or Replace?

For some larger motors running for long periods at high load, some motor users consider that it can make economic sense to replace a standard efficiency motor with a higher efficiency motor - even if the motor is still working satisfactorily.

When it is essential to keep a drive or process operational, the cost of downtime and the quickest way of reinstating the drive will dominate this decision. If the motor is a common rating and speed, it may be available from stock - and in this case, if a choice exists, a higher efficiency motor should be bought. But in other cases - for instance with special machines - repair may be quicker and cheaper.

However, if there is less urgency to replace or rewind the motor, e.g. when a spare motor exists or the motor is used less frequently or in less critical applications, lifetime cost calculations should be performed to determine whether repair or replacement with a higher efficiency motor is more economic.

Opting for motor replacement provides an opportunity to purchase a higher efficiency motor and thus obtain a 3% improvement in motor efficiency. However, the benefit will actually be greater, because even if proper care is taken during repair, the efficiency of the repaired motor will fall by, say 0.5%. The net difference in efficiency between a new higher efficiency motor and a repaired motor could therefore be 3.5%. Although the cost of repairing a motor is usually less than the cost of buying a new one, the energy savings from buying a new higher efficiency motor can, therefore, make this a more attractive option.

Modern HEMs are likely to suffer much lower losses in efficiency after being rewound, as the steel laminations within many of them are better able to cope with the high oven temperature required for the removal of old windings.

Calculating the Payback on Buying a New HEM Compared to Repairing a Standard Efficiency Motor

Table 2 (see Section 5.1.1) shows the comparative running costs of higher efficiency motors and standard motors. The payback on buying a new higher efficiency motor compared to rewinding a failed standard motor is calculated using the following formula:

$$\text{Payback (years)} = \frac{\pounds_{\text{hem}} - \pounds_{\text{old}}}{\text{kW} \times \text{hrs} \times \pounds_{\text{elc}} \times [1/(\eta_{\text{std}} - \eta_{\text{chg}}) - 1/\eta_{\text{hem}}]}$$

where:

- \pounds_{old} = cost of rewind
- \pounds_{hem} = cost of replacement higher efficiency motor
- kW = average power drawn by motor while running
- η_{std} = efficiency of the existing motor before failure*
- η_{hem} = efficiency of replacement higher efficiency motor
- η_{chg} = loss of efficiency after rewind
- hrs = annual running hours of the motor
- \pounds_{elc} = cost of electricity

* This value is often difficult to obtain, but typical figures for older motors are shown in Table 2.

Table 3 gives an example of the economic analysis of replacing a motor with a higher efficiency motor compared to repairing it. This table is for illustrative purposes only and neither the cost of motors nor the results should be used as general guidance. Payback on a new HEM compared to a rewind standard motor varies between 8 and 23 months with the two motor duties shown.

Table 3 Illustration of a cost comparison* between repairing and replacing a 30 kW motor with an HEM

	Standard motor	After rewind	Higher efficiency motor	Difference**
Efficiency	90.5%	90.0%	92.5%	3.0%
Input power	33.15 kW	33.33 kW	32.43 kW	0.90 kW
Cost of repair/purchase		£850	£1,100	£250
Case 1: 8,000 hrs pa at 100% load				
Annual energy use	265.1 MWh	266.6 MWh	259.5 MWh	7,200 kWh
Annual energy cost	£13,260	£13,332	£12,973	£359
Case 2: 4,000 hrs pa at 75% load				
Annual energy cost	£4,970	£4,999	£4,865	£134

* Assumes an electricity cost of 5p/kWh.

** Between a rewind standard motor and a new HEM.

It is important to emphasise that the decision to replace or repair on the basis of lifetime costs depends on many site specific data, e.g. running hours, load, cost of electricity, costs of new or repaired motors, etc. It is therefore important to calculate what is best for your site. Setting up a computer spreadsheet to automate these calculations will allow you to develop a table specific to your company. Alternatively, some motor suppliers may do this for you. A final step could be to draw a graph that shows the economic decision for each motor replace/repair decision (see Fig 8). Such a graph should greatly assist subsequent repair/replace decisions.

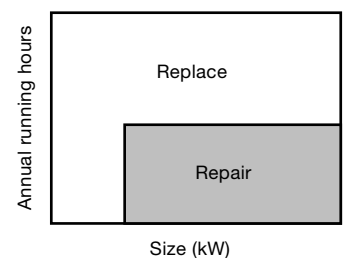

Fig 8 Replace versus rewind

5.3 Motor Sizing

Because most loads are usually found to be around two-thirds of the motor rating, modern motors are usually designed to have a peak efficiency at less than full load.

Modern motors are generally designed for maximum efficiency at 75% full load and between 50 - 100% there is only a minimal variation in efficiency (see Fig 5). However, a significant reduction in efficiency occurs at loads of 25% full load or less, and it is at this level that serious consideration should be given to fitting a smaller motor.

It is important to remember that it is the load that determines how much power the motor draws. The size of the motor does not necessarily relate to the power being drawn. For example, a fan requiring 15 kW could be driven by a 15 kW motor - in which case it is well matched. It could also be driven by a 55 kW motor, and although it would work, it would not be very efficient. However, connecting it to a 10 kW motor would soon cause the motor to trip out. This example shows the importance of knowing the actual power drawn by the motor.

5.3.1 Opportunities for Downsizing Motors

In general, packaged equipment such as compressors which run at or near rated conditions include a motor that is well matched to the driven equipment and the operating duty. There is little scope in these cases for fitting a smaller, lower-rated motor.

However, there is likely to be scope for downsizing the motor in applications where:

- Fan and pumpsets, for example, have been purchased off-the-shelf. These usually operate at a lower output power than they were designed for.
- Purpose-built systems have been designed by the project engineer. The motor rating usually incorporates a high level of contingency.
- Production changes have reduced the load on the motor.

Fig 9 shows some of the reasons why motors can be oversized.

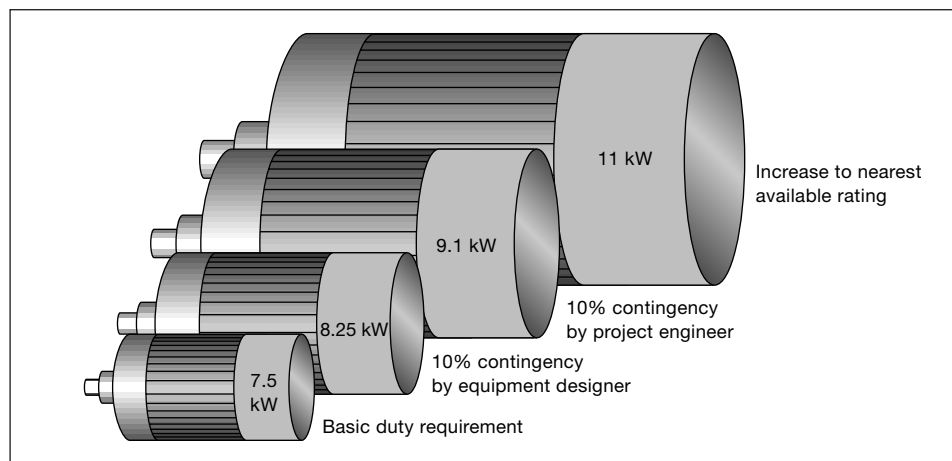

Fig 9 Reasons why motors can be oversized

Some very old motors using considerable amounts of copper and lamination steel had good efficiency figures and come close to today's HEMs. The results may be disappointing if such a motor is replaced on the grounds of energy efficiency alone.

There are two main opportunities for replacing a motor with a smaller one:

- If the decision is taken to replace a failed motor rather than repair it, buying a smaller motor will not only reduce running costs but also save on the purchase price.
- Even if the motor is still working, it may be worth replacing if it is greatly oversized.

Both of these decisions should be taken as part of a motor management policy (see Section 5.7).

5.4 Practical Considerations When Changing a Motor

When changing to a smaller or higher efficiency motor, it is important to consider:

- *Motor length and fixings.* In some cases, the replacement motor may differ in foot fixings, length of the non-drive end and, possibly, in shaft height, diameter and extension. The necessary mounting changes and modifications should therefore be taken into account when determining the financial case for change.
- *Running temperature.* Higher efficiency motors operate within the same Class B temperature limits as standard motors but will not dissipate as much heat.
- *Maximum power capability.* Before changing to a smaller, lower-rated motor, it is important to check that no load will arise which will exceed this new rating.
- *Motor protection.* The change to the new motor should be accompanied by modifications to protection settings and fuse ratings. Many motors now are fitted with thermistors for thermal overload protection; these should be connected and used.
- *Motor slip.* The characteristic ‘slip’ of a motor affects the running speed of a motor and can thus have an impact on energy consumption. (See Appendix 1.2 for more details.) The reduced slip of some modern high efficiency motors can lead to control difficulties in some very specialist applications (such as rock crushers or surface grinders) where there can be very rapid increases in load.
- *Starting torque.* When consideration is being given to fitting a smaller motor, the starting duty in the application should be checked. This is because the starting torque developed by the new, lower-rated motor is likely to be less than the existing motor. In cases where the existing drive is star/delta started, a change to direct-on-line start can be considered.
- *Special loads.* Many drives provide starting and acceleration torque to the load as their main function, e.g. centrifuges or flywheels on presses. The running current of these machines, i.e. when full speed is achieved, is quite low and may give the impression that downsizing or star reconnection is possible. Such cases are unsuitable for application of this energy saving opportunity, but this should be easily established by measuring the starting current.

If it is planned to replace a motor when it fails, remember to take any necessary measurements before failure occurs.

Many modern higher efficiency motors have both higher starting torque and higher locked rotor currents. These facts need to be taken into account in some applications.

CASE STUDY: CHANGING TO HIGHER EFFICIENCY MOTORS

The BBC uses a large number of smaller motors in the heating and ventilation plant at its Brentwood film and video store. Energy costs were reduced by replacing a failed motor and a working standard motor with new higher efficiency motors. At the same time, the opportunity was taken to achieve further energy savings by fitting smaller motors working nearer to their peak efficiency. The overall payback on these two simple measures was less than a year.

Further details are in Good Practice Case Study GPCS266 *Higher Efficiency Motors on HeVAC Plant*, available from the Energy Efficiency Enquiries Bureau.

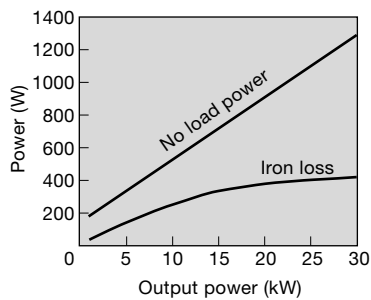

Fig 10 No load power and iron loss of typical four-pole induction motors

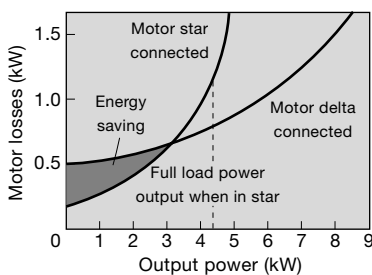

Fig 11 Energy savings from star connection on a 7.5 kW motor

5.5 Reducing Losses in Lightly Loaded Motors

Motors running at low load are inefficient because the fixed losses are disproportionately high (see Section 2.1). This is why the correct sizing of motors is so important.

At low load, the power needed to magnetise the steel causes a major loss in efficiency, i.e. the iron loss. Fig 10 shows the power loss of an induction motor at no load and the proportion of this loss which is due to iron loss.

The iron loss can be reduced by lowering the voltage across each of the motor windings. Since the loss is proportional to the voltage squared, lowering the voltage can - over a limited range - more than offset the increase in current that normally occurs when there is a low supply voltage. A net energy saving can therefore be achieved.

Using a smaller motor - where possible - reduces the amount of iron to be magnetised, and hence the iron loss. An additional benefit is that the iron loss is largely reactive, and so reducing the voltage can have a particularly beneficial effect on the power factor.

Two other ways of achieving a similar effect are permanent connection in star and energy optimising. However, the energy saving from these two techniques can never be greater than the iron loss. Smaller energy savings are obtained with higher efficiency motors due to their lower iron losses.

5.5.1 Permanent Connection in Star

Connecting a motor in star (see Appendix 2) reduces the voltage across the motor windings to 58% of the voltage when running in delta, and the motor gives one third of the torque. At loads below 40 - 45% of rated power, useful energy savings can be achieved by permanently connecting the motor in star (see Fig 11).

To avoid overheating the motor, always check that the line current in star does not exceed the current in delta. If the motor was started direct-on-line, also check that there is adequate starting torque. Practical information on making the change is given in Good Practice Case Study GPCS267.

On smaller motors with six terminals designed for dual voltage operation, i.e. 220 - 240 volts single phase/380 - 420 volts three phase, the motor is normally connected in star for higher voltage operation and so this method is not applicable.

Some equipment with an on/off control, e.g. certain air compressors, may be fitted already with an automatic arrangement to switch to star connection when running at low load.

CASE STUDY: PERMANENT CONNECTION IN STAR

A fan on an air handling unit at the BBC's Brentford film and video store was found to be running constantly at low load. It was decided to reduce its energy consumption simply by reconnecting it permanently in star. This no cost action saved £84/year, giving an immediate payback.

Further details are in Good Practice Case Study GPCS267 *Permanent Star Running of a Lightly Loaded Motor*, available from the Energy Efficiency Enquiries Bureau.

5.5.2 Energy Optimising

'Energy optimisers' - also known as 'motor controllers' or 'power factor controllers' - are connected between the motor and the mains supply. At low load, they can reduce the iron loss by chopping the waveform - using thyristors or triacs - and thus reduce the average voltage and current. This technique can sometimes give reasonable energy savings in some applications with long running hours, mainly at very low load.

Various techniques are used for determining the optimum voltage reduction, including:

- monitoring the power factor;
- monitoring the back electromotive force (emf);
- simply reducing the voltage by a set amount without any sensing at all.

Table 4 offers approximate, but simple, guidance for estimating the potential for energy savings from using an energy optimising control. Sometimes energy saving claims can be misleadingly high - remember that the energy saving can never exceed the total iron loss.

Table 4 Potential energy savings from energy optimising

Motor load	Effect on energy consumption
Less than 1/3 load	Useful energy savings possible.
Between 1/3 and 2/3 load	Not much effect.
Greater than 2/3 load	Energy consumption may increase.

If the motor always runs at low load, consider fitting a smaller motor or connecting the existing one permanently in star. Loads that can be slowed down may produce better savings from being run at a lower speed (see Section 6). If the motor is spending long periods of time idling, then automatic switching off should be considered (see Section 3.1).

Energy optimising is available as standard on some soft starters (see Appendix 2) and some VSDs (see Section 6.5).

Always check that an energy optimiser can respond fast enough for the load and that it will not have any other adverse effects. If uncertain, check with the motor/equipment manufacturer that fitting an energy optimising device will not invalidate the warranty.

Although this Guide provides some indication, predicting the energy savings from energy optimising is difficult. The best advice is often to 'try it and see'.

The results of tests with refrigeration compressors fitted with energy optimising devices are described in Appendix 3.

A significant apparent energy saving shown by a reduction in the current may be largely due to an improving power factor. The number of kWh used - which is what you pay for - may not have fallen by nearly as much.

5.6 Motor Maintenance

Although the maintenance needs of cage induction motors are minimal, periodic attention should be given to the following to maintain a high operating efficiency:

- Many smaller motors (up to around 22 kW) are fitted with sealed-for-life/shielded bearings as standard. Where appropriate the motor bearings should be greased in accordance with the manufacturer's instructions and always replaced with the correct parts.
- Good motor shaft to load alignment reduces running losses, bearing wear, noise and vibration (see Section 4.2.3).
- Overall cleanliness is important to ensure that the heat generated within the motor is effectively removed. Fan inlets and frame surfaces should be kept clear of deposits. Also make sure air flow over the motor is not obstructed, particularly at the non-drive end near the fan inlet. An increase in the stator winding temperature of 1°C can produce an increase of up to 0.5% increase in the I²R loss (see Section 2.1), as well as shortening the life of the motor insulation.

5.7 Motor Management Policy

A motor management policy that incorporates the following features will help to keep running costs down. These are:

- a systematic maintenance programme;
- a clear purchasing policy to buy HEMs where feasible;
- replacement or rewinding of failed motors based on lifetime costs.

5.7.1 Motor Management Agreements with External Contractors

Some companies offer a complete repair/replacement service for all motors within a company or on a site. Others will even assume ownership of all the motors and, for a fixed annual fee, keep them running by either repair or replacement.

Both of these services are a convenient way of managing the complexities of deciding whether to repair or replace, while ensuring that company policy is maintained.

CASE STUDY: MOTOR PURCHASING POLICY

ECC International Europe has a policy of using higher efficiency motors wherever this is cost-effective. This Case Study examines the selection of suitable applications at the Company's St Austell china clay plant. The figures show that, even with the cost premium of £16,050 that existed in 1992 for the 76 higher efficiency motors considered, the overall energy savings were £12,000/year.

Further details are in Good Practice Case Study GPCS222 *Purchasing Policy for Higher Efficiency Motors*, available from the Energy Efficiency Enquiries Bureau.

6. SLOWING DOWN THE LOAD

Since most systems operate for much of the time below their rated capacity, methods of reducing the output to a level that matches the demand have to be found. The dampers, throttles, recirculation systems and pressure relief valves that are often used are very energy inefficient. Reducing the speed of the load e.g. the fan or the pump, is a much more efficient way of achieving the same effect.

6.1 Types of Load

The potential energy savings from slowing down the load depend on the load characteristics - of which there are three main types, i.e. variable torque, constant torque and constant power.

6.1.1 Variable Torque

The fundamental laws governing the operation of centrifugal fans and pumps mean that these applications have the largest energy saving potential. The affinity laws (see Fig 12) state that torque varies with the speed squared and power with the speed cubed, i.e.:

- flow \propto speed;
- pressure or torque \propto speed²;
- power \propto speed³.

The power speed relationship is sometimes known as the ‘power cubed’ law or as the ‘square torque’ law. Controlling flow by reducing the speed of the load means that a relatively small speed change produces a large fall in absorbed power.

6.1.2 Constant Torque

For applications such as positive displacement air compressors, conveyors, agitators, crushers and surface winders, the torque does not vary with speed and the power is directly proportional to the speed (see Fig 13), i.e. the energy consumed is directly proportional to the useful work done.

Although the potential energy savings from speed reduction are not as large as for square torque law applications, they are still worth investigating. Halving the speed of a constant torque load can halve the energy consumption - the actual savings depend on the previous control system.

6.1.3 Constant Power

The third type of load characteristic is where the power does not vary with speed and the torque is inversely proportional to speed (see Fig 14). Applications include machine tools and centre winders.

There is rarely scope for energy savings from speed reduction in constant power applications.

Speed control is a much more energy efficient method of regulating flow than throttles, dampers or recirculation systems.

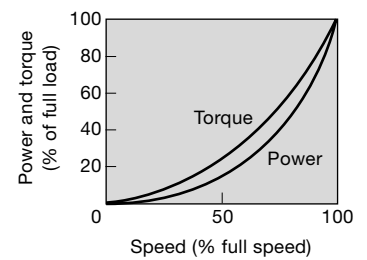

Fig 12 Variable torque load

Impressive energy savings can be achieved on a square law torque, e.g. reducing the speed by 20% can reduce the energy consumption by $(0.8 \times 0.8 \times 0.8) \approx 50\%$.

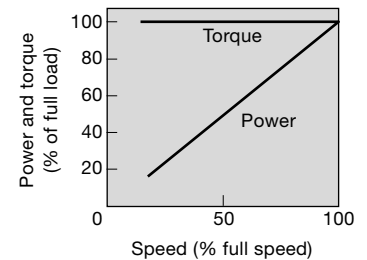

Fig 13 Constant torque load

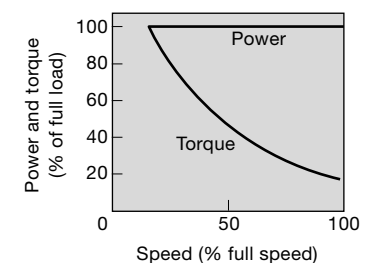

Fig 14 Constant power load

6.2 Energy Efficient Flow Reduction

A machine always operates where its pressure:flow characteristics match those of the system. For example, for the fan with the characteristics shown in Fig 15 and operating in a system with the flow-dependent frictional loss characteristic shown, the operation point will be at A.

One way of reducing the flow is to insert a damper. This would increase the system frictional characteristics, as shown in Fig 15, giving a new operating point, B. Although the flow falls as desired, the power reduction is very small. A similar effect is obtained when a throttle is fitted to a pump system.

A better approach is to vary the machine characteristics by reducing the speed. The new machine characteristics for a reduced speed give a new operating point, C (see Fig 15). Since the power used by the fan is proportional to the flow multiplied by the pressure, while the flow is the same as for B, the power is much less.

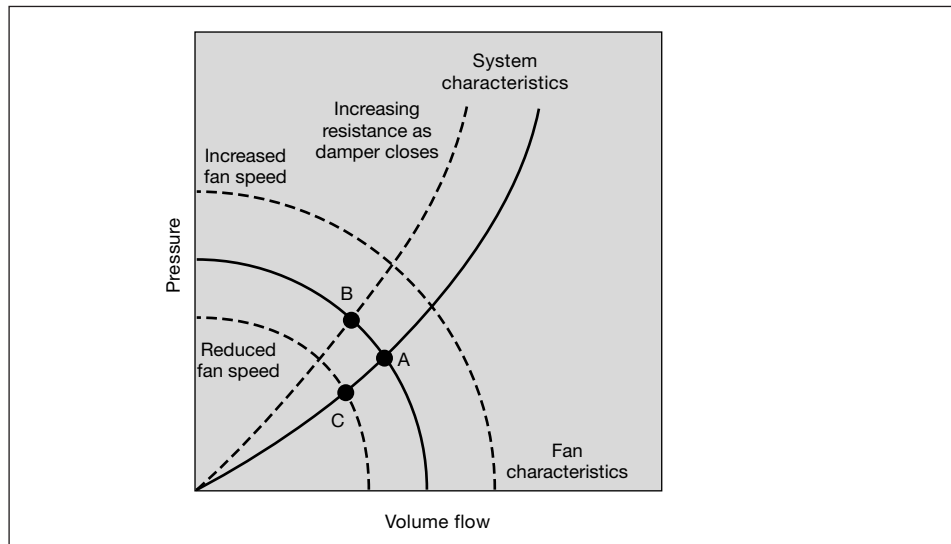

Fig 15 A typical fan characteristic showing the operating point

Any method of speed reduction will give the same effect. However, a variable speed drive permits operation anywhere on the machine curve and is generally the popular choice.

6.3 The Effects of Static Head

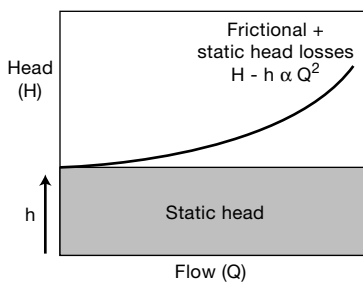

Fig 16 Total system resistance from frictional losses plus static head losses

The power cubed law assumes that the system characteristic is entirely made up of frictional losses due to resistance in the piping. However, in some pumping systems operating against a high pressure, e.g. mains water systems or boiler feedwater pumps, a significant proportion of the energy used for pumping may be used to maintain this static head (see Fig 16). This can severely restrict the potential for speed reduction because even if no flow is required, the pump has to keep operating at a minimum speed just to maintain the static head.

6.4 Ways of Changing the Speed of the Driven Machinery

In its most basic form, the induction motor is a fixed speed device when operated from a constant frequency and constant voltage supply. However, several techniques exist to provide different or variable speeds from an induction motor (see Table 5). Changing the pulley and gearbox ratio are listed in Table 5 because, although the speed of the motor is not altered, the speed of the load (e.g. pump, fan) will change. The important point is that it is the work done by the driven machine (which is proportional to the speed) that determines the motor power consumption. The speed of the fan or pumps could simply be changed by altering the transmission ratio and keeping the motor speed the same.

Table 5 Ways of changing the speed of a motor-driven load

Method	Comments
Variable speed drives (See Section 6.5)	Used where several discrete speeds or an infinite number of speeds are required. Many other benefits make them the usual choice, but often the most expensive option.
Multiple speed motors (See Section 6.6)	Used where two, and up to four, distinct duties exist.
Use a different speed standard motor	The speeds available are discussed in Appendix 1.
Changing the pulley ratio on a belt drive (See Section 6.7)	Low-cost option. Used when operation at a fixed speed is sufficient.
Change the gearbox ratio	

Electronic VSDs, which are becoming both cheaper and more versatile all the time, are usually the preferred choice for speed control.

6.5 Variable Speed Drives (VSDs)

An electronic variable speed drive for AC induction motors (see Fig 17) - also known as an inverter - works by first converting the AC mains supply to DC using a rectifier. After smoothing by a filter, the DC supply is chopped by six transistors at a high frequency in such a way as to produce a variable frequency, variable voltage at the terminals of the motor and thus enable the induction motor to be run efficiently at different speeds (Fig 18).

In addition to the huge potential for saving energy by slowing down the motor in many applications, the use of electronic variable speed drives has other important benefits, including:

- improved process control and hence enhanced product quality;
- programmable soft starting, soft stopping and dynamic braking;
- wide range of speed, torque and power;
- facility to control multiple motors;
- unity power factor;
- dynamic response comparable with DC drives;
- by-pass capability in the unlikely event of VSD failure.

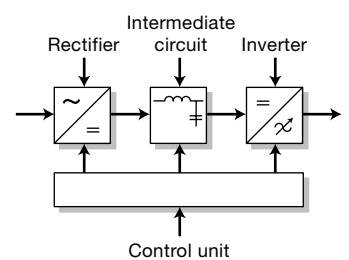

Fig 17 The main features of an electronic variable speed drive

The many other benefits of VSDs should be taken into account when making the case for purchasing a VSD for energy saving.

Your local distributor may loan you a VSD to verify the estimated savings before you make the final decision to buy.

Two basic types of control are available:

- Manual control of speed. This can either be varied manually or just set up and left.
- Automatic control of the speed using feedback from the process being controlled to adjust the speed automatically. This is ideal for situations where there is a varying demand.

VSD Technology

Most drives are now controlled by pulse width modulation (PWM), in which the voltage waveform delivered to the motor is synthesised by high frequency switching of the devices in the output inverter. The efficiency of a PWM drive is typically about 95%. Although many VSDs now have advanced control features, they all possess the same basic energy saving capability.

This synthesised waveform has a small amount of harmonic distortion (shown much exaggerated in Fig 18), which will increase motor losses. In some cases, de-rating may be necessary, although less likely if the user is prepared to permit the winding temperature to rise to the full class 'F' temperature limit of 105K.¹ It is also important with older motors to check that the insulation can withstand the higher peak voltages due to inverter operation.

The development of *vector drives* with 'near DC' performance makes VSDs feasible for applications where DC motors and controllers were previously necessary.

Switched reluctance drives (SRDs) are particularly suited to high speeds and have a good dynamic response, but require a special type of motor. Use of SRDs has so far been limited to niche applications, and to cases where the motor drive and the driven equipment are fully integrated. However, SRDs are expected to become more common.

Improvements in VSD Technology

The considerable progress made during the last decade in the performance of electronic VSDs for induction motors means that these units are now the preferred choice for most variable speed applications. The improvements have been made possible through the use of both more powerful semiconductor devices that can be switched faster and cheaper processors for control.

The main effects of these improvements are:

- reduced cost;
- improved performance, especially in dynamic control;
- better output waveforms, resulting in reduced motor noise and lower power loss;
- greater flexibility of control;
- improved VSD input stages, offering reduced line harmonics, unity power factor, regeneration and active filtering;
- much higher reliability (long guarantee periods are now available from many manufacturers).

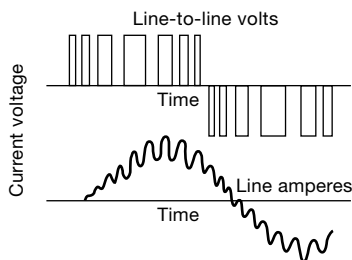

Fig 18 PWM inverter waveforms

¹ It is usual for motor manufacturers to quote ratings on the basis of a class 'B' temperature rise of 80K. This gives a margin of safety since class 'F' insulation or better is now used in induction motors. However, outputs for VSDs are often quoted using class F temperature rise in order to minimise de-rating.

6.5.1 *Equipment with a built-in VSD*

Buying equipment system with a built-in VSD is usually cheaper than buying the equipment and the VSD separately. For example, for an air compressor with an integral VSD, the effective premium paid for the VSD is comparatively small because the costs of the gearbox and some other components are eliminated. Many other types of equipment are now becoming available with built-in VSDs, e.g. pumps, fans and air conditioning units.

When buying equipment from an original equipment manufacturer (OEM), ask if it can be supplied with a VSD as standard.

6.5.2 *Integrated Motor Drives*

A recent innovation is the introduction of combined motor and VSD packages where the VSD is mounted ‘piggy-back’ style on top or at the end of the motor. This has several advantages over separate units, including:

- lower total cost;
- reduced wiring time;
- no electromagnetic interference (EMI) emissions from the motor side inverter leads, cables or cabling;
- optimum matching of the motor to the VSD.

6.5.3 *Energy Optimising Feature on VSDs*

Many VSDs now have an energy optimising feature (see Section 5.5.2) incorporated in their design which can be useful with slowly varying loads. This feature reduces the output voltage at low loads and thus reduces the iron loss (see Section 2.1).

The energy saving, which is in addition to that from slowing down the load, is difficult to estimate. Although it is unlikely that the savings from the energy optimising feature alone would be sufficient to justify the purchase of a VSD, they do provide a useful bonus at little or no additional cost when at low speeds. This is particularly true for applications where the motor is oversized.

6.5.4 *Practical Considerations When Using VSDs*

When using VSDs, it is important to consider:

- *Motor heating.* For cubed law applications, the power demand falls so rapidly that additional cooling is unnecessary. A separate fan is therefore only required for constant torque loads.
- *Increased speed and power.* Inverters present the opportunity of running at speeds higher than the rated speed. In a square torque law application, it should be remembered that a 10% increase in speed raises the delivered power by 33% and the torque by 21%.
- *Hazardous areas.* Unless they have been specifically designed and certified for this purpose, electronic variable speed drives must be located outside hazardous areas. VSDs intended for use in hazardous areas should be engineered at the plant design stage and preferably designed to ‘flameproof’ or Eex d classification. Other classifications are possible, although these often involve substantial certification costs.

Retrofitting inverters for use with existing hazardous area motors requires careful consideration. It is essential to check with the manufacturer that certification exists or can be obtained.

- *Electromagnetic compatibility (EMC).* Most manufacturers incorporate special filters to limit the amount of conducted emissions imposed on the mains supply. The length of wiring should be kept to a minimum, care should be taken with the layout and all motor side cables should have earthed screens. Specialist advice can help to avoid problems.

Ask your VSD supplier for further information on EMC in particular products.

6.6 Multiple Speed Motors (MSMs)

Multiple speed motors can be a lower cost alternative to a VSD in cases where a drive has 2 - 4 distinct operating conditions, each with different flow requirements, e.g. a cooling tower fan where there may be seasonal changes, shorter term process changes or longer term changes in manufacturing demand. However, the relative coarseness of the speed control means that a multiple speed motor cannot be used for close system regulation.

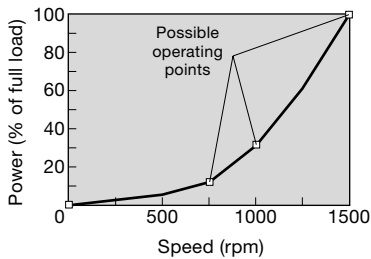

Fig 19 Power consumption at different MSM working points

Many standard motors may appear to have two speeds indicated on their nameplate, e.g. 1,500/1,800 rpm, but these represent the speeds when connected at 50 Hz and 60 Hz.

Distinct operating conditions can often be foreseen at the design and installation stage, for example in the case of a hoist or with machine tools. If the differing power conditions only become evident when a plant has been operating for some time, it can still make economic sense to replace an existing motor with an MSM.

Fig 19 shows the relationship between energy consumption and speed for a square torque law load at different MSM working points.

6.6.1 Different Types of MSMs

There are three main types of multiple speed motor.

- *Multiple winding motors.* These machines have two or more completely separate windings, each with a different pole number and providing a different speed. This arrangement wastes space in the motor since only one winding is energised at any time. A two-speed motor with two separate windings is usually one frame size larger than its single-speed equivalent.
- *Pole-changing motors.* All the windings are utilised in these motors for each of two or three separate speeds. They are therefore more economical than multiple winding motors. A 2:1 ratio is achieved by reconnection of pole groups within the winding; a 3:2 ratio can also be obtained, but a 3:1 ratio is unusual.
- *Pole-amplitude-modulated (PAM) motors.* This technique avoids the need for two or more separate windings and provides a wider variety of speed ratios than can be obtained with the more conventional pole-changing motors.

Table 6 gives a sample of the range of speed changes that can be achieved with pole-changing motors and PAM motors.

Table 6 Speed ratios most commonly obtainable from multiple speed motors

Pole-changing motors	PAM motors
3,000/1,500 rpm	1,500/1,000 rpm
1,500/750 rpm	1,500/375 rpm
1,000/500 rpm	1,000/750 rpm
	1,000/375 rpm
	1,000/300 rpm
	750/600 rpm
	375/150 rpm

Extra terminals are provided in all multiple speed motors; arrangements have to be made to detect or decide when a speed change is required and to switch the windings accordingly (usually with additional contactors). The starters for controlling motors with separate windings are less expensive than those for pole-changing or PAM motors.

It is normally possible to replace an existing single-speed motor with a new pole-changing or PAM motor type without having to change fixing arrangements or shaft height.

CASE STUDY: USE OF A MULTIPLE SPEED MOTOR

The Suffolk Coastal District Council swimming pool previously used a fixed speed fan in the air handling units. The management realised that the much lower ventilation requirement at night meant that there was the potential to save energy by reducing the fan speed during this period.

A two-speed 4/8 pole (6.5/1.5 kW) motor was fitted as a low cost way of reducing the fan speed at night. The energy saving of £1,200/year gave a payback of 21 months on the £2,080 cost of a replacement two-speed motor. However, if this motor had been specified from new, the price premium would have only been £450 - giving an even more attractive payback of just over four months.

**Further details are in Good Practice Case Study GPCS219
Two-speed Motors on Ventilation Fans, available from the Energy
Efficiency Enquiries Bureau.**

6.7 Changing the Pulley Ratio

When looking at belt drives, take the opportunity to re-tension the belt (see Section 4.2.2)

Changing the pulley ratio in belt driven equipment is probably the cheapest way of reducing the speed. Example applications include fans operating permanently against dampers, or blowers operating against pressure relief valves.

The savings can be substantial in relation to the modest cost of a pulley change, giving the potential for payback periods of a few days (see example below).

In some cases, the reduced demand for airflow may not be permanent. This need not be a problem - either retain the original pulleys or fit a multiple speed block. Some equipment, such as HeVAC units, are provided with multiple speed pulley blocks to allow the output to be altered during commissioning - use these rather than fitting external dampers.

The risk of slippage if the high speed pulley is too small means that there are limitations to the range of pulley ratio which can be used. The fan manufacturer can usually advise on the limits for particular applications. An alternative is to use split pulleys which can be adjusted to give a different diameter over a limited range.

Example Savings from Changing the Pulley Ratio on a Fan

Examination of the duty of a fan extraction system driven by a motor drawing 10 kW suggested that the fan speed could be reduced to 85% of its original value, i.e. from 1,000 rpm to 850 rpm (see Fig 20). To achieve this speed reduction, the fan pulley diameter was increased from 200 mm to 235 mm.

New power consumption = $(850/1,000)^3 \times 10 = 6.1$ kW (a saving of 3.9 kW).

CASE STUDY: CHANGING THE PULLEY RATIO

Modifications to the process plant at the Westmill Foods rice mill at Selby meant that there was a reduced air demand on the pneumatic conveying system. As a result, considerable quantities of air were being lost from the pressure relief valve on the Roots blower. The Company recognised that this was wasting a significant amount of energy and changed the pulley ratio of the belt drive. This gave a speed reduction of 39% and produced a decrease in power consumption from 22.2 kW to 9.6 kW. The saving of £4,960/year was achieved for a capital expenditure of only £58.

Further details are in Good Practice Case Study GPCS337 *Low Cost Speed Reduction by Changing Pulley Sizes*, available from the Energy Efficiency Enquiries Bureau.

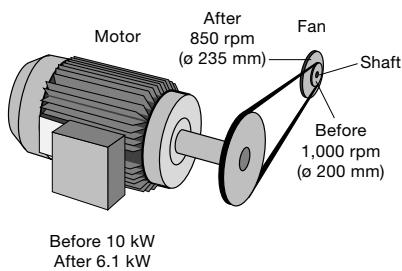

Fig 20 Changing the pulley ratio on a fan

6.8 Speed Control of Centrifugal Pumps

There are several ways of reducing the flow in pumping systems, but as shown in Fig 21, none are as effective as actually reducing the speed of the pump.

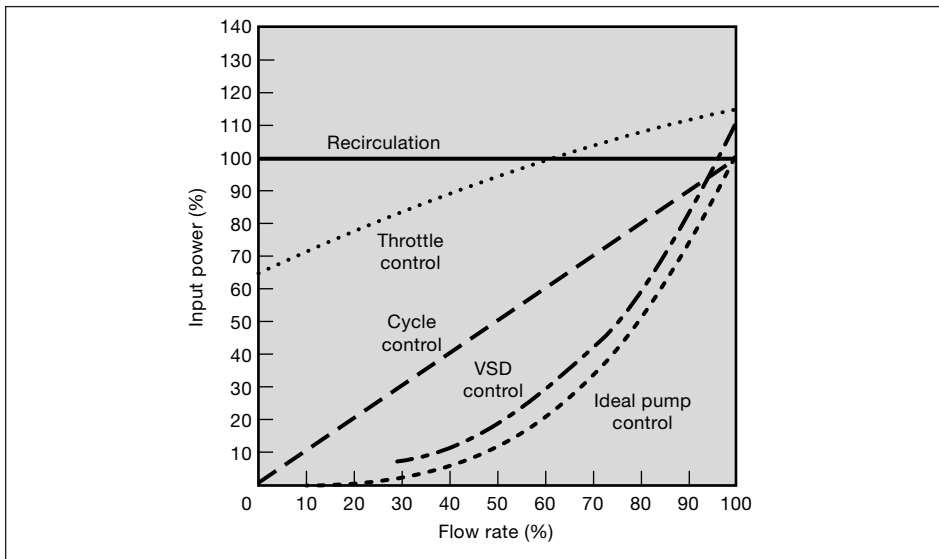

Fig 21 Power requirements of different pumping control options

Throttling is the commonest method of flow regulation, but the efficiency is poor because the pump is not being run at its design point (see Fig 22). This is particularly true for pumps with a steep flow/head (Q/H) characteristic and for small pumps. The power losses for a throttle-regulated system are shown in Fig 23.

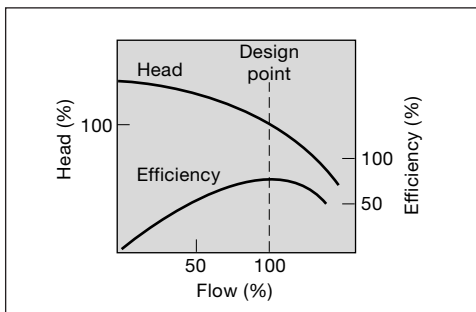

Fig 22 Typical centrifugal pump curve

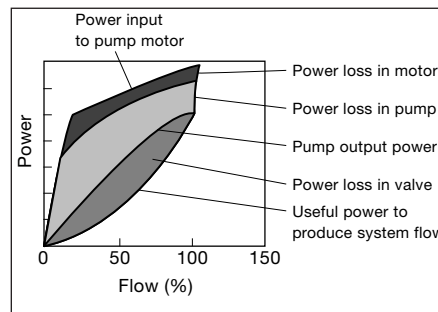

Fig 23 Power consumption in fixed speed pumping

Typical pump characteristics for a speed controlled pump and the power savings compared to throttle control are shown in Figs 24 and 25 respectively.

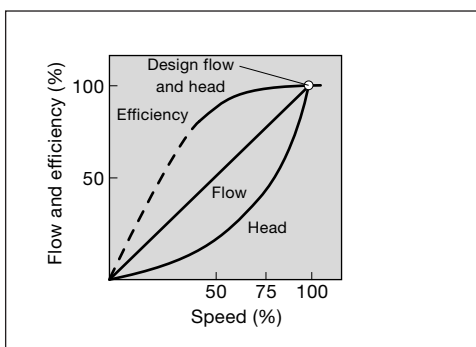

Fig 24 Typical pump characteristics for variable speed

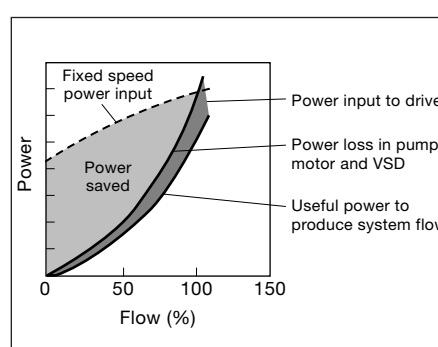

Fig 25 Power consumption and energy savings using a VSD

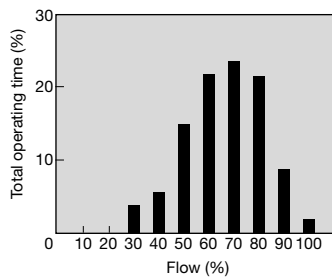

Fig 26 Typical centrifugal pump duty cycle

General Information Report 41, Variable Flow Control, discusses the control of fans and pumps in building services applications.

Use of VSDs can also reduce pump cavitation and eliminate water hammer (due to their soft starting feature).

Possible pumping applications where VSDs can be used include:

- mains water pumping where extensive pipework systems are dominated by friction losses and where the flow varies considerably (see Fig 26);
- pump switching between systems with different characteristics;
- batch processes with cycles requiring varying flow rates;
- constant flow systems with a system pressure that varies, e.g. due to the use of liquids with variable viscosity.

CASE STUDIES: VARIABLE SPEED DRIVES FOR PUMPS

The water supply for the Stoke-on-Trent factory of Creda Ltd, which is distributed via a 6 inch ring main, is taken from the Severn Trent mains supply and a private borehole. The 30 kW borehole pump was previously throttled to ensure that the licensed quota was not exceeded, while water pumped by a 15 kW pump from the mains supply was recirculated through a pressure relief valve to maintain a constant supply pressure.

Fitting the borehole pump with a VSD and opening the throttle fully saved £4,100/year, for an investment of £2,450. The mains water pump was also fitted with a VSD and the pressure relief valve closed. This gave a saving of £3,460/year on an investment of £2,800 - a payback of ten months. The system pressure is now maintained by a pressure transducer controlling the pump speed.

Further details are in Good Practice Case Study GPCS088 *Variable Speed Drives on Water Pumps*.

The air handling unit (AHU) temperature on the large centralised chilling systems at Manchester Airport had been set by three-way valves diverting excess cold water back to the main chillers. The total investment of £49,600 in VSDs to match the flow to the demand has produced savings of £26,800/year, giving a payback of just under two years.

Further details are in Good Practice Case Study GPCS089 *Variable Speed Drives on Cooling Water Pumps*.

The large secondary refrigeration system at Ind Coope's Romford site was driven by a 75 kW pump, with a pressure regulator to bypass excess coolant. This system was inherently inefficient, particularly in cool weather. A VSD was fitted to maintain the set pressure electronically using a pressure transducer to control the pump speed. Energy savings of £7,960/year were achieved for a capital cost of £11,500, giving a payback of 1.5 years.

Further details are in Good Practice Case Study GPCS124 *Variable Speed Drives on Secondary Refrigeration Pumps*.

**CASE STUDIES: VARIABLE SPEED DRIVES FOR PUMPS
(CONTINUED)**

At its Newport works, Cray Valley Ltd uses large quantities of cooling water in the production of polymers and resins. VSDs were fitted to pumps on two water cooling systems, thus allowing the flow to be altered to suit the demand. These VSDs cost £10,000 each and gave paybacks of 1.9 and 1.4 years. A hydraulic pump motor used to vary the speed on a stirrer was replaced by an 18.5 kW electric motor and a VSD. Energy savings of £1,780/year were achieved. The changes cost £4,300, giving a payback of 2.4 years.

Further details are in Good Practice Case Study GPCS170 *Variable Speed Drives in a Chemical Plant.*

The original laminar plate water cooling system at the Redcar plant of British Steel Sections, Plates and Commercial Steels was provided by four pumps working at full flow irrespective of production patterns. VSDs were fitted to the pumps to control the flow so as to be proportional to the cooling demand. Energy savings of £65,500/year were achieved from a capital investment of £214,000, giving a payback of 3.3 years.

Further details are in New Practice Final Profile NPFP079 *Variable Speed Drives on a Steel Mill's Water Pumping System.*

The Iggesund Paperboard AB pulp mill at Iggesund, Sweden, achieved energy savings of 18 kWh/tonne of pulp by fitting VSDs to the medium consistency pumps. Electricity consumption fell by 26%, while the overall payback was two years.

Further details are in CADDET Result 163 *Speed Control of Pumps Saves Energy at a Pulp Mill.*

All of these publications are available from the Energy Efficiency Enquiries Bureau.

6.9 Speed Control of Fans

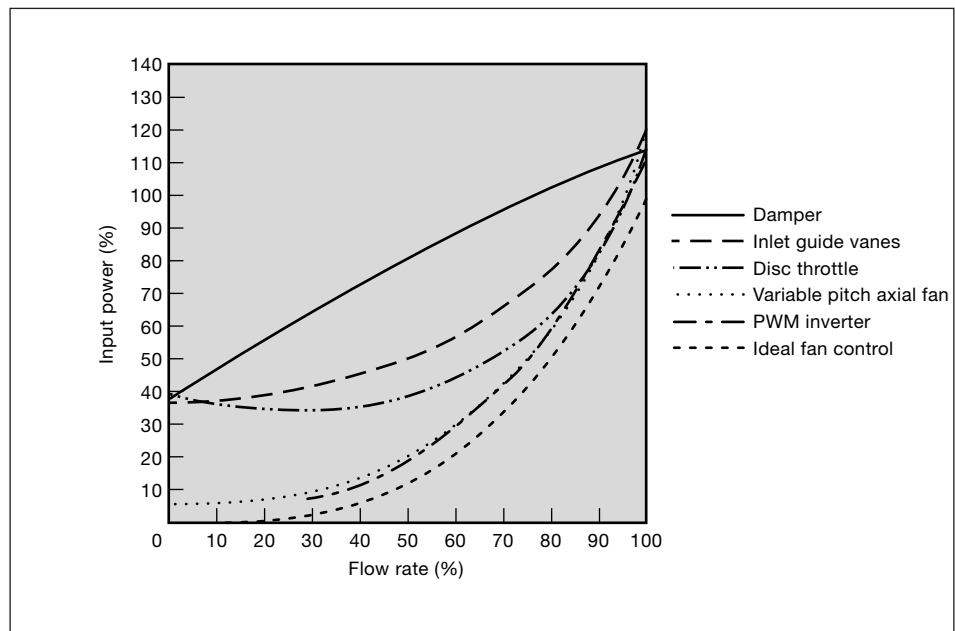

Fig 27 Fan power requirements with different control methods

Various fixed speed methods of restricting flow are also used on fixed speed fan applications. Variable speed control to match the fan to the system characteristics (regulation) is the most energy efficient (see Fig 27).

Other benefits of VSDs in fan applications include:

- improved combustion on boilers, especially when used with oxygen trim;
- reduced noise in heating and ventilation air duct systems due to elimination of dampers.

Examples of energy savings from a wide range of applications are described below.

CASE STUDIES: VARIABLE SPEED DRIVES ON FANS

Glasgow Royal Infirmary carried out an in-house survey to identify likely energy saving applications for VSDs. The low average steam demand suggested that the dampers controlling the air flow on the 45 kW induced draft fan of the main 40,000 lbs/hr boiler could be replaced by a VSD. The annual savings obtained with the VSD were £8,300/year, giving a payback of 11 months on capital expenditure of £7,100.

Further details are in Good Practice Case Study GPCS035 *Variable Speed Drive on a Boiler Fan.*

CASE STUDIES: VARIABLE SPEED DRIVES ON FANS
(CONTINUED)

Combustion air demand on the batch furnaces at Stocksbridge Engineering Steels was controlled by a butterfly flap in the air duct. The cyclic nature of the process meant that the fan was running for long periods in a heavily damped position. Replacing this butterfly flap with a VSD to control fan speed gave savings of £1,535/year for a capital cost of £3,000 - a payback of just under two years.

Further details are in Good Practice Case Study GPCS125 *Variable Speed Drives on a Batch Furnace Combustion Air Fan.*

Dust was extracted from the Rank Hovis Trafford Park flour mill by up to four 75 kW fans, with fine control of the air flow being achieved by dampers. Tests showed that the fan speed could safely be reduced to a minimum of 80% of the rated speed. Investment of £12,900 in a VSD gave energy savings with a payback of 1.0 - 2.6 years, depending on the mode of operation.

Further details are in Good Practice Case Study GPCS164 *Variable Speed Drives on a Flour Mill Extract Fan.*

Ducal Ltd manufactures a wide range of pine furniture at its Andover plant, where the dust produced by the various pieces of machinery is removed by a large extraction system. Ducal fitted several VSDs to save energy - all controlled by simple logic. One VSD was fitted to a bank of three pieces of equipment, with the fan speed altered according to the number of machines operating; on another, the fan was permanently set to a lower speed. The total energy savings on the overall investment of £9,000 were worth £5,800/year, giving a payback of 19 months.

Further details are in Good Practice Case Study GPCS232 *Variable Speed Drives for Wood Dust Extract Fans.*

Cyanamid UK produces a range of synthetic drugs on a batch basis at its Gosport plant. The variable load on the cooling towers means that, for long periods of time, the fans are generating much more airflow than required. Fitting a VSD to alter the fan speed according to the water return temperature gave total savings worth £7,590/year on expenditure of £5,400, a payback of 8.5 months.

Further details are in Good Practice Case Study GPCS270 *Variable Speed Drive on a Cooling Tower Induced Draught Fan.*

British Steel Stainless uses four 1,200 kW extract fans for fume cleaning in its melting shop. To reduce the airflow at times when the furnace or vessel is on hold, VSDs were fitted to the two duty fans. Fan speed was controlled by a signal from an obscuration meter that the fume density was kept to an allowable level. The capital cost of £384,000 produced energy savings of £166,500/year, giving a payback of 2.3 years.

Further details are in New Practice Final Profile NFPF66 *Variable Speed Drives and Obscuration Meters on a Large Fume Cleaning Plant.*

All these publications are available from the Energy Efficiency Enquiries Bureau.

6.10 Speed Control of Air Compressors

Rotary screw and piston air compressors are essentially a constant torque load, with the savings from the use of variable speed control dependent on the control system that is being replaced.

Fig 28 shows the energy savings achieved by fitting a VSD to a rotary screw compressed air unit compared to other methods of flow control at part load.

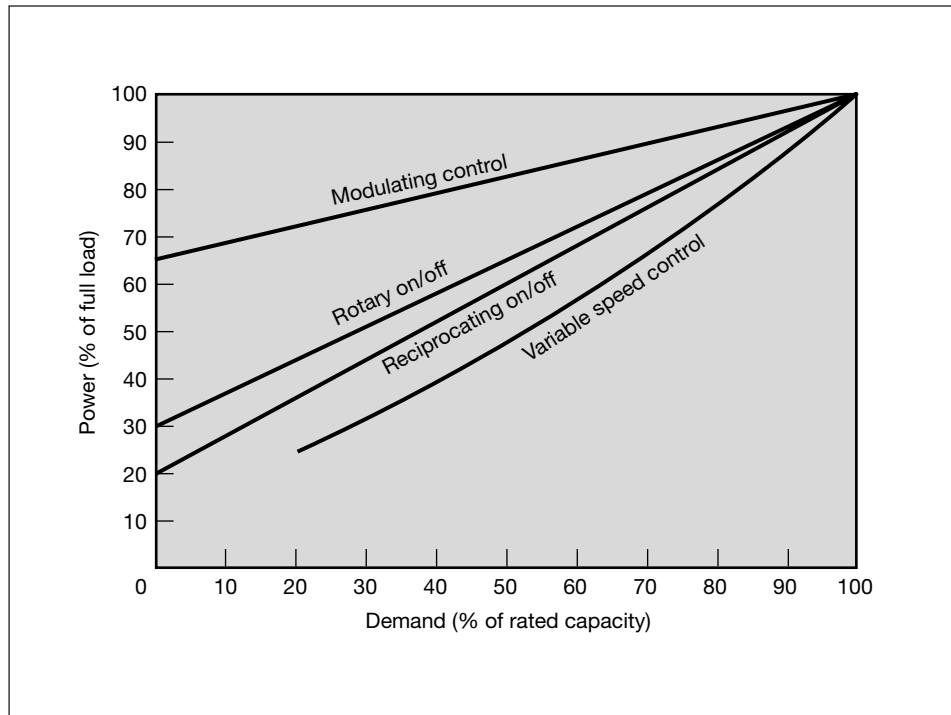

Fig 28 Energy saved by using a VSD on a rotary screw air compressor

The energy savings with a constant torque load will be considerably less than with centrifugal pumps or fans which obey the power cubed law, and so it is less likely to be economic to retrofit a VSD to a compressor on the grounds of energy savings alone. In addition, care needs to be taken to ensure adequate lubrication at reduced speeds. For this, and other technical reasons, the manufacturer should always be consulted if retrofitting a VSD is contemplated.

However, the introduction of screw compressors with integral speed control has enabled the additional price of variable speed control to be significantly reduced, so these machines should therefore be considered for all new applications with long running hours, where there is a widely varying demand.

Further energy savings will also be achieved through closer pressure control reducing the mean generation pressure, and there may also be further cost savings through improved process quality.

7. TAKING ACTION

Decisions on the priorities and measures to be taken to reduce energy consumption in motor drives are not always easy. This is due to three main factors:

- The large number of motor drives on the site - coupled with the variety of applications and sizes - makes it difficult to know where to start looking.
- Collecting data on which to base decisions can be expensive and time consuming, and it is not obvious which data are needed.
- A number of energy saving measures are possible, but it is not obvious which, if any, provides the best technical and financial case.

Winning management commitment for an energy saving policy is often the critical factor in ensuring long-term success.

Fig 29 shows a systematic procedure that can be used as a long-term framework for action.

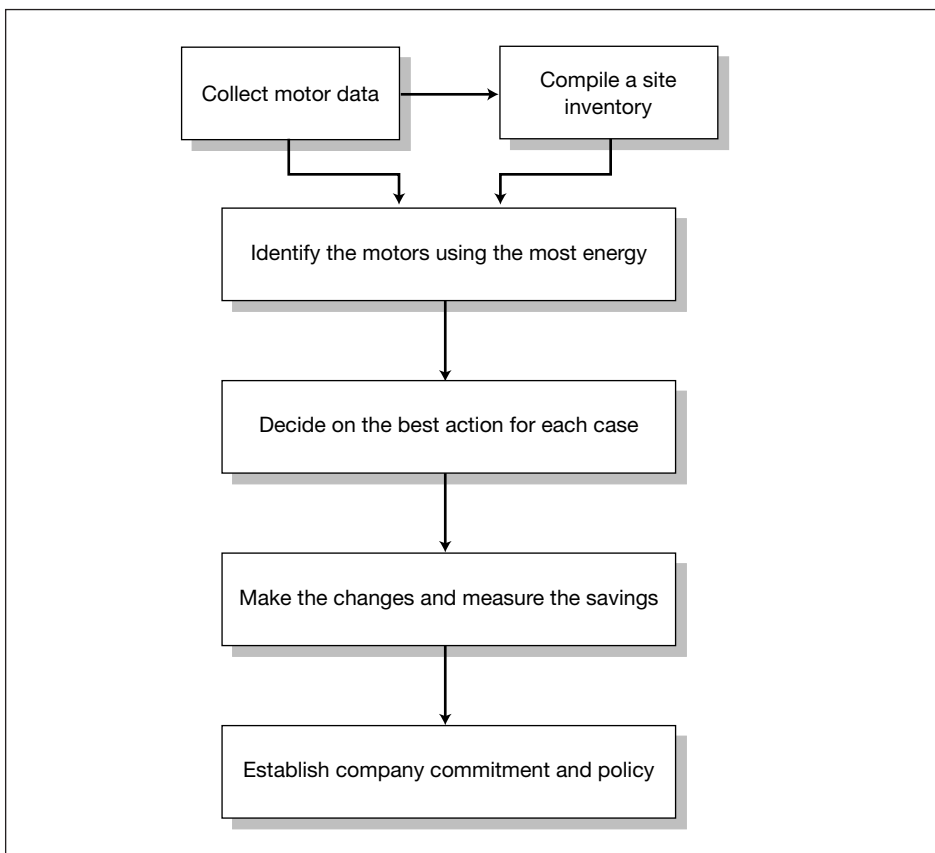

Fig 29 An action plan to reduce energy use by motor drives

7.1 Where to Start?

The best place to start is by looking at those motors with the highest energy consumption.

7.1.1 *Estimating Running Costs*

A crude, but simple, method of estimating the possible running cost of a motor or any other load is to multiply together:

- the rated power of the motor;
- the annual number of running hours;
- the average cost of electricity in £/kWh.

For example, the approximate cost of an 11 kW motor running for 5,000 hours/year at a cost of 4.5 p/kWh is (11 kW x 5,000 hours x 4.5 p/kWh) = £2,475/year.

This calculation ignores motor efficiency and actual load conditions, but it does provide a quick estimate of potential running costs without having to take measurements. It also provides a useful pointer as to where to concentrate efforts.

Using this approach, the average cost of running each kW of motor capacity on the site can be readily calculated. This calculation provides a figure that can be used to quickly estimate running costs. For example, on a site where electricity costs 4.5 p/kWh and assuming an average motor efficiency of 90%, then it will cost £400 to run 1 kW of motor load for one year.

Estimated costs (as shown in Table 7) soon identify the big energy users. This approach can be further refined if the actual load can be estimated.

Table 7 Approximate motor running costs*

Motor size	Annual running hours	Annual cost
1.1 kW	8,000	£440
11 kW	8,000	£4,400
22 kW	2,000	£2,200

* Assuming 1 kW of motor load costs £400/year to run.

The more energy a motor uses, the greater the potential to save energy.

7.2 Deciding on a Course of Action

The numerous choices mean that no simple formula exists for characterising different situations and deciding which measures are most appropriate. However, a good approach is to look systematically at each application and ask the following questions:

- Is the equipment still needed?
- Can it be switched off? (See Section 3)
- Can the motor load be reduced? (See Section 4)
- Is it the most efficient motor for the job? (See Section 5)
- Can it be slowed down? (See Section 6)

The checklist at the end of Section 1 summarises these options.

Remember:

- Cost-effective actions are likely to come from more than one of these categories.
- One action will affect the cost-effectiveness of another, e.g. switching off a motor will reduce its running hours and hence the amount of energy that could be saved by fitting a VSD.

For all applications, fit HEMs from new. Consider VSDs on centrifugal fans or pumps.

Although experience has shown that most energy is saved by the wider use of higher efficiency motors and VSDs, it is important not to forget the many other simple, low cost energy efficiency measures.

An existing inventory used for maintenance purposes could be a good starting point for a site motor inventory.

7.3 Making an Inventory of Motor Drives

A list of motor drives operating on the site can be compiled, with each motor assigned a number for future reference. Fig 30 indicates suggested information that should be recorded for each motor on a site.

SITE	Central	MOTOR REF	C/W2/M367
APPLICATION	Pump	LOCATION	Warehouse 2
NAMEPLATE DETAILS			
MANUFACTURER	A.N. Other	SERIES	Premium
RATED POWER	7.5 kW	POWER FACTOR	0.83
SPEED	1,500 RPM	FULL LOAD CURRENT	14.8 AMP
		SERIAL NUMBER	
DESCRIPTION OF EQUIPMENT			
Cooling water supply pump for warehouse			
NOTES ON MOTOR DUTY			
Motor running 24 hours a day at an estimated 2/3 load, but actual water demand varies greatly. Fitted with a throttle.			
REPAIR HISTORY			
Installed	Nov 1975		
Rewound	Aug 1984		
Rewound	July 1993		
ACTIONS			
Replace with HEM at next failure Consider fitting a VSD			

Fig 30 Example page from a motor inventory

Compiling an inventory performs a number of functions:

- It provides a clear framework for identifying the applications to look at first and for justifying further measurements on individual drives.
- The audit may highlight immediate no-cost or low-cost energy saving opportunities.
- The audit may highlight an imminent or existing malfunction.
- A properly maintained log enables rapid and accurate repair/replace decisions to be taken if and when a motor fails (see Section 5.2.1).

From an energy saving point of view, it is not economic to include in the inventory motors below a certain rating, operating load or running hours. These low energy users can simply become part of an across-the-board site motor policy, with only low-cost or easy to implement measures undertaken. This often means waiting until the equipment needs replacing.

7.4 Taking Measurements

The aim of a measurement programme is to obtain sufficient information to determine, with a reasonable degree of certainty, which measures will produce acceptable savings. The type of measurements made should depend on what the information is needed for - there is no point in collecting more information than is necessary.

Measurements should also be taken after the energy saving action has been implemented so that:

- there is confidence that the right measure has been taken;
- evidence is available to confirm the justification for expenditure;
- future proposals for energy efficiency projects will be accepted more readily by management.

Too much data can result in 'analysis paralysis'. Just deciding to switch off a washroom ventilation fan at weekends is such an obvious action that no measurements need to be taken.

Measuring Power

The power consumption of a three-phase motor is given by the following formula:

$$\text{Power (kW)} = \frac{\sqrt{3} \times V \times I \times \cos \phi}{1,000}$$

where: V = voltage (volts)
 I = current (amps)
 cos φ = power factor.

The only practical way to measure power consumption accurately is with a power meter or an energy analyser. Just multiplying together the values of the voltage and the current from separate meters will merely give the kVA = (√3 x V x I)/1,000. The kWh (i.e. kW x hours), which takes into account the power factor, is what you pay for and this is what is important.

Some tariffs penalise a poor power factor (see Fig 31). Ways of improving the power factor (and hence reducing the kVA) are discussed in Fuel Efficiency Booklet FEB9A *The Economic Use of Electricity in Industry*.

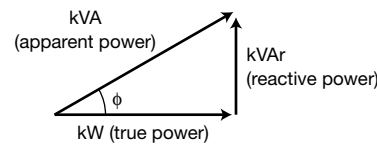

Cosine φ = Power factor

Fig 31 Relationship of kW, kVA and kVAR

7.4.1 Deciding Which Data to Collect

- *No measurements.* Knowledge of the operating regime can be adequate for compiling an inventory list and spotting any obvious low cost energy saving opportunities.
- *Running hours.* Often just knowing what shift pattern some equipment is working will give an adequately accurate idea of the running hours. However, permanent meters may already be fitted for maintenance purposes; modern field sensing types for temporary measurements do not need any electrical connections.
- *Spot check of current.* A spot check of motor current consumption, if it is known to be steady, can provide useful information. If the current reading is close to the nameplate value, then the motor is near full load; if it is only a fraction of this value, it is at low load. This knowledge may be adequate for some purposes. N.B. Using current measurements and estimated power consumptions for loading between these extremes can be very misleading. This is because it does not take account of the changes with load, of power factor or motor efficiency.
- *Power measurement.* In cases where a large capital investment is being considered, e.g. a VSD, it may be worth using a power meter to record power consumption over a period of time. Most models can export data to a PC for further analysis.

The potential savings from fitting VSDs can be estimated from power consumption data together with an appropriate measure (or estimate) proportional to the system demand, e.g. air or water flow (see Fig 32). The potential energy savings from flow reduction is a function of the difference between the actual flow and the estimated required flow. In centrifugal fan and pump applications, the power cubed law means that the potential energy savings rise very rapidly as this difference in flows increases. Many VSD suppliers provide software which automatically calculates the potential energy savings from fitting a VSD.

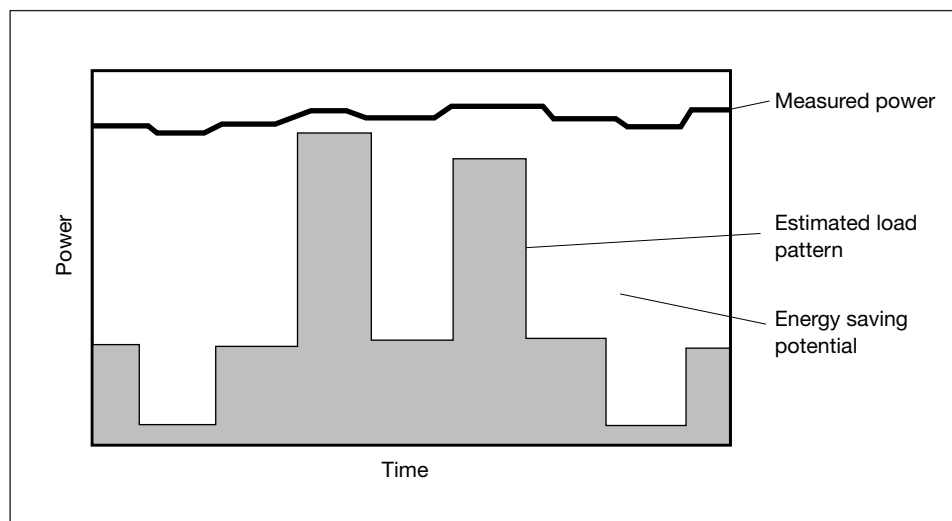

Fig 32 Load profile of a possible VSD application

7.5 Establish Company Commitment and Policy

For any scheme to be successful there must be:

- commitment from senior management;
- clearly defined programme responsibility;
- sufficient resources for both planning and implementation.

These rules should be complemented by a core company policy based on simple and unambiguous guidelines (see Fig 33). This policy should evolve to take account of practical experience and changed circumstances.

The advantages of having a company policy on motors are that:

- there is no need to prepare a separate case for each purchase decision;
- all levels in the company are given the authority to purchase equipment not solely on the basis of first cost;
- energy saving opportunities are not lost due to the time taken to obtain approval;
- time is not wasted repeating detailed and costly calculations;
- the policy becomes a valuable summary of site experiences;
- the policy demonstrates the company’s commitment to energy efficiency and encourages further action.

Making it happen... Good Practice Guide GPG213 ‘Successful Project Management for Energy Efficiency’ contains practical advice on how to make sure your ideas become a reality.

**Our Company Policy
on Motors**

Always buy higher efficiency motors from new.

Unless a motor is needed urgently, use the Company repair/replace selection chart to decide what to do when a motor fails.

Always consider fitting variable speed drives to pumps and fans above 7.5 kW operating double shift or more.

Fit kWh meters to all equipment overkWh/year.

All motors abovekW should be included in the site motor inventory.

The person responsible for the programme is



Signed
Managing Director

Fig 33 Example company policy on motors

8. **FURTHER INFORMATION**

8.1 **Energy Efficiency Best Practice Programme and CADDET Publications**

Key:	FEB	Fuel Efficiency Booklet
	ECG	Energy Consumption Guide
	GPG	Good Practice Guide
	GPCS	Good Practice Case Study
	NPPF	New Practice Final Profile
	NPR	New Practice Report
	FPR	Future Practice Report
	FPP	Future Practice Profile
	GIR	General Information Report
	VI	Video
	R	CADDET Result Brochure
	D	CADDET Demonstration Brochure

The following publications are available from the addresses shown on the back cover of this Guide.

Motors

FPR050	Higher Efficiency Induction Motors
VI010	Making Motors Pay Dividends
GPCS162	High Efficiency Motors on Fans and Pumps
GPCS215	Automatic Switch-off of Power Presses
GPCS222	Purchasing Policy for Higher Efficiency Motors
GPCS266	Higher Efficiency Motors on HeVAC Plant
GPCS267	Permanent Star Running of a Lightly Loaded Motor.

Speed Control

GIR41	Variable Flow Control
GPCS035	Variable Speed Drive on a Boiler Fan
GPCS088	Variable Speed Drives on Water Pumps
GPCS089	Variable Speed Drives on Cooling Water Pumps
GPCS124	Variable Speed Drives on Secondary Refrigeration Pumps
GPCS125	Variable Speed Drives on a Batch Furnace Combustion Air Fan
GPCS126	Variable Speed Drives in a Bakery
GPCS164	Variable Speed Drives on a Flour Mill Extract Fan
GPCS170	Variable Speed Drives in a Chemical Plant
GPCS219	Two-speed Motors on Ventilation Fans
GPCS232	Variable Speed Drives for Wood Dust Extract Fans
GPCS270	Variable Speed Drive on a Cooling Tower Induced Draught Fan
GPCS337	Low Cost Speed Reduction by Changing Pulley Size
NPPF066	Variable Speed Drives and Obscuration Meters on a Large Fume Cleaning Plant
NPPF079	Variable Speed Drives on a Steel Mill's Water Pumping System
R163	Speed Control of Pumps Saves Energy at a Pulp Mill

Compressed Air

VI006	Compressing Air Costs
GPG126	Compressing Air Costs
FEB004	Compressed Air and Energy Use
ECG040	Compressing Air Costs- Generation
ECG041	Compressing Air Costs - Leakage
ECG042	Compressing Air Costs - Treatment
GPCS136	Cost and Energy Savings Achieved by Improvements to a Compressed Air System
GPCS137	Compressed Air Costs Reduced by Automatic Control
GPCS233	Energy and Cost Savings from Air Compressor Replacement
GPCS276	Energy Management in a Manufacturing Company
GPCS277	Refurbishment of a Compressed Air System

Refrigeration

GPG036	Commercial Refrigeration Plant: Energy Efficient Operation and Maintenance
GPG037	Commercial Refrigeration Plant: Energy Efficient Design
GPG038	Commercial Refrigeration Plant: Energy Efficient Installation
GPG042	Industrial Refrigeration Plant: Energy Efficient Operation and Maintenance
GPG044	Industrial Refrigeration Plant: Energy Efficient Design
ECG037	Cold Storage Sector
FEB011	The Economic Use of Refrigeration Plant
GPCS092	Automatic Purging on a Cold Store Refrigeration Plant
GPCS230	A New Refrigeration System in a Small Cold Store
GPCS248	Energy Savings Whilst Eliminating CFCs with a New Refrigeration System
FPP021	Optimising the Operation and Design of Refrigeration Systems
GIR003	Feasibility and Design Study of Continuously Variable Capacity Refrigeration Plant
R061	Cooling System for Fruit and Vegetable Storage Plant
D015	Energy Efficient Refrigeration/Air Conditioning System

Pumps

GPCS300	Energy Savings by Reducing the Size of a Pump Impeller
---------	--

Electricity and Power Quality

FEB009A	The Economic Use of Electricity in Industry
---------	---

8.2 Other Publications

Electrical Energy Efficiency, Copper Development Association Publication No. 116, *Common Power Quality Problems and Best Practice Solutions*, Copper Development Association Publication No. 111

Available from:

Copper Development Association, Verulam Industrial Estate, 224 London Road, St Albans, Hertfordshire AL1 1AQ. Tel: 01727 731200. Fax: 01727 731216.

The Repair of Induction Motors, Association of Electrical and Mechanical Trades. Available from: AEMT, 177 Bagnall Road, Basford, Nottingham NG6 8SJ. Tel: 0115 978 0086. Fax: 0115 978 4664.

APPENDIX 1

MOTOR SPEED

A1.1 Motor Speed and Number of Poles

The speed of an induction motor is given by the formula:

$$\text{Speed of rotation (rpm)} = 120 \times \text{supply frequency} / \text{number of poles.}$$

Table 8 Available motor speeds

No. of poles	rpm
2	3,000
4	1,500
6	1,000
8	750
10	600
12	500

The nominal speeds that are available when operating at 50 Hz are listed in Table 8.

The use of motors with high pole numbers may seem an attractive idea for running at low speeds. However, such motors are relatively unusual and, for induction motors with high pole numbers, the power factor and efficiency become very low. Two, four, six and eight pole motors are available as standard; ten or twelve pole motors are available, but not as readily. This is mainly because lower speed motors need to be physically larger for the same power rating, and thus cost more.

A1.2 The Effect of Load on Motor Speed

The synchronous speed described above is effectively the 'no load' speed. However, as the motor load increases, the motor slows down slightly, by an amount known as the slip². The slip is determined by the torque/speed characteristic of the motor (see Fig 34), although most are built to similar standards. At no load, the slip is very small; at full load, it typically increases to around 4% - the shaft speed therefore falls slightly from the synchronous value (see Fig 34).

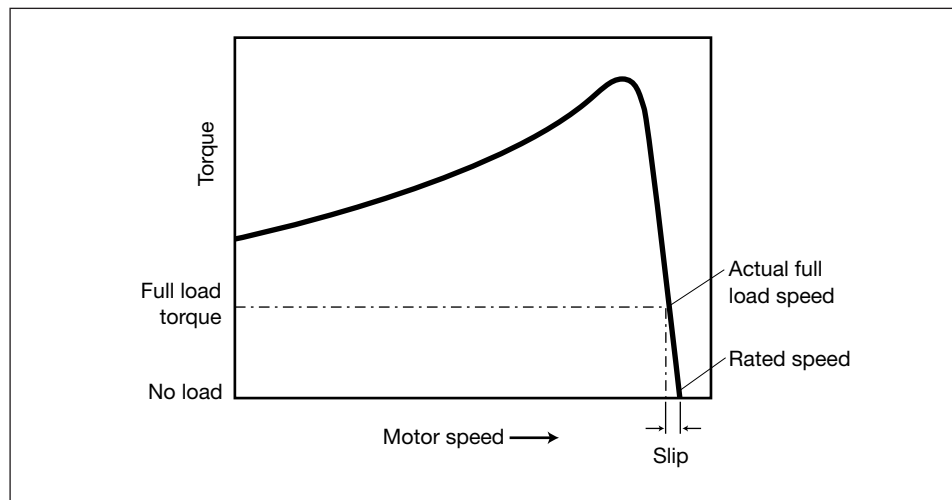

Fig 34 Torque-speed characteristics for cage induction motors

Fitting a higher efficiency motor as a replacement motor could - if the slip is considerably less than on the original motor and driving cubed law loads - lead to an increase in energy consumption. However, this is rarely a problem and, provided the motor-driven load and its system are properly controlled, then the power consumed by the motor will decrease as expected.

² $\text{Slip} = 1 - \frac{\text{rotor speed}}{\text{rotating field speed}}$

where the rotating field speed is determined by the supply frequency.

APPENDIX 2

MOTOR STARTING

The 'direct-on-line' starting current for an induction motor can be six or seven times the normal full load current. In some circumstances - and especially for smaller motors - this high starting current is acceptable, but for larger machines, the demand on the local electrical system may be too great and the stress on the machine windings may be excessive.

Other starting methods always reduce the starting torque as well as the starting current; this can be useful in protecting the driven equipment, e.g. a belt, or products on a conveyor. However, too little torque could mean that the motor cannot start the load.

A2.1 Star/Delta Starting

In most three-phase induction motors, both ends of each phase winding are brought to terminals so that the machine can be connected in star or in delta (see Fig 35). In star connection, the voltage across the phase winding is reduced to 58% of that in delta: the motor therefore presents a higher impedance to the supply and the starting current is limited to one third of the starting current for delta connection. Full torque - and hence power consumption - is only developed when the change to delta is made. This transition from star to delta connection is usually made by a timed contactor.

To reduce energy costs, low loaded motors can be connected permanently in star - at virtually no cost (see Section 5.5.1).

A2.2 Electronic Soft Starting

One alternative is the electronic soft starter, which uses a simple device such as a triac to delay the switching on of the voltage every cycle and thus reduce the effective voltage applied to the motor.

Apart from a small energy saving during ramp-up, the soft starter does not reduce the energy drawn by the motor. However, it reduces the mechanical wear during starting and stopping, thus allowing energy to be saved by switching motors off more frequently.

Many soft starters now incorporate an energy optimising feature to provide additional energy savings when running for long periods at very low load. On larger units, however, it is usual to bypass the soft starter once the motor is running on load to avoid the power loss from the thyristors or triacs in the unit.

A2.3 Current Profiles During Starting

Fig 36 compares the current during starting with typical star/delta, direct-on-line and soft starting arrangements. Depending on the exact re-closing of the starter contactors when switching to delta, it is possible to see transient current as high as 1,200% (12 x full load current), with a corresponding high-torque transient.

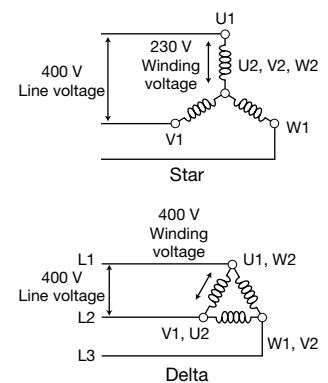

Fig 35 Star and delta connection of a three-phase motor

Soft starting is incorporated in all VSDs as standard.

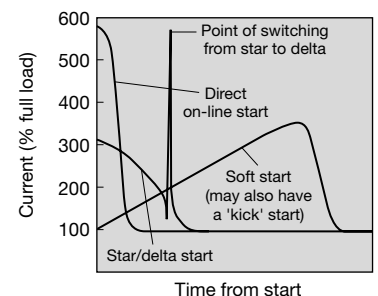

Fig 36 A comparison of current profiles during starting by star/delta, direct-on-line and soft starting

APPENDIX 3

USE OF ENERGY OPTIMISERS ON REFRIGERATION COMPRESSORS

This Appendix applies only to domestic refrigerators/freezers and integral commercial units such as chilled display cabinets and chest freezers.

The characteristics of refrigeration compressors fit the basic criteria for fitting energy optimisers, i.e. long running hours mainly at low load. Various tests have been carried out by independent bodies (see below) to assess the performance of energy optimisers in this application. The tests indicate that large chest freezers are likely to benefit most from these devices. The energy savings from fitting energy optimisers to domestic refrigerators, dairy cabinets, ice cream cabinets and drinks cabinets are less attractive than those obtained with chest freezers.

Domestic Freezers and Fridge-freezers Fitted with Energy Optimisers (ETSU for the Department of the Environment now the Department of the Environment, Transport and the Regions, 1990)

The energy consumption of 50 domestic freezers and fridge-freezers in the Bracknell area was monitored for six weeks with, and six weeks without, the device. Excluding extraordinary events such as doors being left open, the energy savings averaged 7.4%, with most appliances showing a saving of 0 - 15%. No correlation between the energy savings and the type or age of cabinet could be found.

Tests Carried Out by EA Technology

These tests, which were funded by the Regional Electricity Companies in 1996, are the most comprehensive set of tests yet undertaken on these devices. The tests involved monitoring identical appliances in a temperature-controlled environment over a period of three months. Pairs of identical appliances - one with and one without an energy optimiser - were subject to identical loading cycles that mimicked typical conditions. The devices were fitted in turn to both appliances in each pair to eliminate the effect of variations in the appliances.

The energy savings in the EA Technology tests were:

Large chest freezers³: 6%
Ice cream cabinets: 3.8%
Drinks cabinets: 2.9%
Dairy cabinets: 2% (increase).

These figures show the average energy savings achieved in these tests. Some individual cabinets may experience an increase in energy consumption.

³ However, the different devices tested showed different average energy savings in the range 0 - 15%. The thermostat of one freezer under test completely failed to operate, i.e. the freezer was unable to cope with the load. For freezers where the thermostat was operating properly, the mean cabinet temperature rose, indicating that the thermostat needed adjusting. Unless temperature is carefully observed, this effect will suggest a reduction in power consumption.

The Government's Energy Efficiency Best Practice Programme provides impartial, authoritative information on energy efficiency techniques and technologies in industry, transport and buildings. This information is disseminated through publications, videos and software, together with seminars, workshops and other events. Publications within the Best Practice Programme are shown opposite.

Further information

For buildings-related publications please contact:
Enquiries Bureau

BRECSU

Building Research Establishment
Garston, Watford, WD2 7JR
Tel 01923 664258
Fax 01923 664787
E-mail brecsuenq@bre.co.uk

For industrial and transport publications please contact:
Energy Efficiency Enquiries Bureau

ETSU

Harwell, Didcot, Oxfordshire,
OX11 0RA
Fax 01235 433066
Helpline Tel 0800 585794
Helpline E-mail etbpenh@aeat.co.uk

Energy Consumption Guides: compare energy use in specific processes, operations, plant and building types.

Good Practice: promotes proven energy efficient techniques through Guides and Case Studies.

New Practice: monitors first commercial applications of new energy efficiency measures.

Future Practice: reports on joint R & D ventures into new energy efficiency measures.

General Information: describes concepts and approaches yet to be fully established as good practice.

Fuel Efficiency Booklets: give detailed information on specific technologies and techniques.

Energy Efficiency in Buildings: helps new energy managers understand the use and costs of heating, lighting etc.